

AGRICULTURE CANADA

- 8 JAN 1932

LIBRARY — BIBLIOTHEQUE

Publication 5002

AGRICULTURAL MATERIALS HANDLING MANUAL

PART 2 CONVEYING EQUIPMENT

SECTION 2.4

UNITIZED CONVEYORS



Agriculture
Canada

630.4
C212
P5002 50/12/11 5.2



Digitized by the Internet Archive
in 2012 with funding from
Agriculture and Agri-Food Canada – Agriculture et Agroalimentaire Canada

AGRICULTURAL MATERIALS HANDLING MANUAL

PART 2 CONVEYING EQUIPMENT

SECTION 2.4

UNITIZED CONVEYORS

The Agricultural Materials Handling Manual is produced in several parts as a guide to designers of materials handling systems for farms and associated industries. Sections deal with selection and design of specific types of equipment for materials handling and processing. Items may be required to function independently or as components of a system. The design of a complete system may require information from several sections of the manual.

L.M. STALEY
DEPARTMENT OF BIO-RESOURCE ENGINEERING
UNIVERSITY OF BRITISH COLUMBIA
VANCOUVER, B.C.

**PREPARED FOR THE CANADA COMMITTEE
ON AGRICULTURAL ENGINEERING SERVICES
OF
CANADIAN AGRICULTURAL SERVICES
COORDINATING COMMITTEE**

PUBLICATION 5002, available from
Information Services, Agriculture Canada, Ottawa K1A 0C7

© Minister of Supply and Services Canada 1981
Cat. No. A21-12/2.4/1981E ISBN: 0-662-11517-1
Printed 1981 1.5M-5:81

TABLE OF CONTENTS

2.4.1	General	6
2.4.2	Pallets	6
2.4.2.1	Purpose of Palletization	6
2.4.2.2	Planning Palletization	6
2.4.2.3	Pallet Design and Selection	7
2.4.2.4	Construction of Pallets	8
2.4.2.5	Preservatives	10
2.4.2.6	Pallet Loading	10
2.4.3	Pallet Bins	12
2.4.3.1	Purpose of Pallet Bin Handling	12
2.4.3.2	Planning a Pallet Bin Handling System	12
2.4.3.3	Construction and Treatment of Pallet Bins	13
2.4.4	Loading of Unitized Conveyors	14
2.4.4.1	Fork Lift	14
2.4.4.2	Belts and Chains	18
2.4.4.3	Tractor-mounted Front End Loaders	18
2.4.4.4	Rear-mounted Loaders	20
2.4.5	Unloading Unitized Material	20
2.4.5.1	Pallet Bin Unloaders	22
2.4.5.2	Vertical Silo Unloaders	23
2.4.5.3	Horizontal Silo Unloaders	24
2.4.5.4	Wagon Unloaders	24
2.4.6	Transport	27
2.4.6.1	Stationary Conveyor Units	27
2.4.6.2	Mobile Conveyor Units	29
2.4.6.3	Hay Handling Units	29
2.4.7	References	35

List of Figures

2.4.1	Aisle Width Allowance for Fork Trucks	6
2.4.2	Double-entry All-purpose Pallet	7
2.4.3	One-way Entry Pallet	8
2.4.4	Double-entry Pallet	8
2.4.5	Container Size Matrix	11
2.4.6	Pallet Pattern Selection Guide	11
2.4.7	Building Pallet Loads	12
2.4.8	Pallet Bin with Corner Posts	13
2.4.9	Pallet Bin with Corner Clamps	13
2.4.10	Plywood Pallet Bin	13
2.4.11	Low-lift Pallet Lift. Useful for Moving One to Two Bins in a Packing House	15
2.4.12	Criteria for Capacity Ratings of Fork Lift Trucks	15
2.4.13	Electric Fork Lift. Useful for Loading, Unloading, Transporting and Stacking Bins in a Packing House	16
2.4.14	Low-lift three-point Hitch Fork Attachment. Bin Transporter Lifts 0.7t up to 400 mm	16
2.4.15	Rear-mounted Bin Stacker Lifts 1t up to 2700 mm	17
2.4.16	Rear-mounted Hydraulic Fork Lift with Hold-down Unit to Lift 1.8t up to 3600 mm	17
2.4.17	Fork Lift Attachment for Front-end Loader	19
2.4.18	Front-end Agricultural Loader Dimensional Specifications	19

- 2.4.19 Typical Front-mounted Silage or Manure Fork. Power is Supplied by the Tractor Hydraulics or an Auxiliary Hydraulic Pump 20
- 2.4.20 Skid-steer Loader for Front-mounted Bucket, Fork or Blade 21
- 2.4.21 Hydraulically Operated Bale Fork for Stacking or Unstacking eight Bales per Operation 21
- 2.4.22 Rear-mounted Loader with Lift Forks and Push Bar for Removing Round Bales or other Loads from Forks 22
- 2.4.23 Hydraulic Bin Dumper - Rotates Bin up to 140° 23
- 2.4.24 Submersion Dumper Used in Okanagan Packing Plants 23
- 2.4.25 Silage Cutter and Concentrate Hopper. Unit is Advanced by Cattle Pressing against the Mangers 24
- 2.4.26 Effect of Tons Removed per Day from Horizontal Silos on Cost per Ton 25
- 2.4.27 Effect of Labor Costs on Costs per Ton 25
- 2.4.28 Effect of Travel Distance on Cost per Ton 25
- 2.4.29 Effect of Removal Time and Equipment Costs on Cost per Ton from Horizontal Silos 25
- 2.4.30 PTO Powered Chain and Slat Self-unloading Wagon 26
- 2.4.31 Self-unloading Wagon Supplies Chopped Forages to Vertical Silo Loader 26
- 2.4.32 ASAE Recommended Hitch and Box Dimensions for Farm Grain Wagons 29
- 2.4.33 Hay Stacker and Mover 30
- 2.4.34 Hay Stacker Former 30
- 2.4.35 Hay Stacker 31
- 2.4.36 Automatic Bale Wagon, Can Pick Up, Load, Transport and Unload in Stacks from 1.8 to 5.5 t per Load 31
- 2.4.37 Pull-type Bale Wagon, Used at a nine-bale High Stack 32
- 2.4.38 Pull-type Bale Wagon, Used to Unload one Bale at a Time onto a Bale Elevator 32
- 2.4.39 Self-propelled Bale Wagon Equipped with a Retriever, to Move Entire Baled Hay Stacks to Feeding Area or Other Stack Location 32
- 2.4.40 Portable Bale Elevator 32
- 2.4.41 Belt-type Round Baler 33
- 2.4.42 Big Bale Fork Attachment for Front-end Tractor Loader, will Handle 1.5 to 2.1 m Bales 33
- 2.4.43 Big Bale Mover with Hydraulic Operated Lift Forks, to Raise Bale onto Transport Bed 33
- 2.4.44 Tilting-bed Big Bale Transported with Twin Transfer Chain 34
- 2.4.45 Tractor Rear-mounted Single Bale Pick-up Attachment. Can be Used for Stacking and Unrolling for Cattle Feeding. 34

List of Tables

- 2.4.1 Division of Common Species of Wood into Three Strength Classes 9
- 2.4.2 Minimum Capacities of Rollers 27
- 2.4.3 Maximum Capacities of Frames 27
- 2.4.4 Specifications of Straight Sections — Aluminum Frames and Wheels 28
- 2.4.5 Specifications for Straight Sections — Aluminum Frames, Steel Wheels 28
- 2.4.6 Specifications for Straight Sections — Steel Frames and Wheels 28

SECTION 2.4 UNITIZED CONVEYORS

2.4.1 GENERAL

Unitized conveyors include pallets, pallet bins, mobile bulk containers, hydraulic buckets, hoists, and similar equipment designed to handle free-flowing and non-free-flowing materials in unit loads.

The necessity for unit handling becomes apparent when damage resulting from continuous handling decreases the quality of the product, or when the cost of individual handling of small quantities becomes excessive. The pallet is an important development in this respect and permits the unit handling of materials in large uniform lots.

The justification for unitized conveying systems must be based on a careful appraisal of alternatives, such as continuous conveying or manual systems. Analysis of the cost for each alternative as well as a proper consideration of available equipment should indicate the correct selection.

2.4.2 PALLETS

A pallet is a portable platform designed to hold one or more boxes, baskets, bales, sacks, etc., in a group, thus permitting the load to be transported and stored as a single unit. The pallet is well suited to handle rectangular containers such as boxes and bales that can be stacked or unitized. Pallet size should be standardized to increase efficiency and facilitate interchange of pallets between similar operations.

2.4.2.1 Purpose of Palletization

1. To decrease cost of handling materials. Several items can be handled at the same time.
2. To increase useable storage space. Stacking loaded pallets one above the other can make greater use of available storage space.
3. To increase rate of materials handling and decrease lost time of prime movers at terminal points. The increased rates allow perishable goods to be handled more rapidly. Refrigerated cars and storages need be opened for shorter periods while handling produce.
4. To provide better protection of the product. Materials or packages handled in unit loads require less handling, resulting in less damage.
5. To provide ventilation channels for products in storage.

2.4.2.2 Planning Palletization

To secure maximum efficiency from palletization, determine the characteristics of the material and the handling method. Also, consider available equipment and estimate the material and building alterations required. The following procedure is useful to analyze the problem:

1. Characteristics of materials handled

- (a) Size, shape, density and quantity.
- (b) Number of units per pallet.
- (c) Handling rate required.

2. Movement and storage requirements

- (a) Intra-plant:
 - Raw material or end product?

- Remote temporary storage, or storage at point of manufacture?
- Route of materials between operations?

(b) Inter-plant:

- Transportation method? (rail, truck, etc.)
- Are pallets expendable?
- If pallets are returnable, by what method?
- Is suitable equipment available for unloading?

3. Characteristics of present or proposed plant

(a) Physical facilities:

- Stacking height available, normally a multiple of palletized load heights, plus ceiling clearance. The latter is to include clearance for lights, sprinkler system, and ventilation when applicable.
- Lateral dimensions, normally a multiple of lengths and widths plus interpallet and wall clearance. This clearance is to be 25 mm (1 in.) on either side of the length of the pallet and 50 mm (2 in.) on either side of the width. If load extends over edge then clearance has to be added to the load dimensions.
- The doorway width and height, aisle width and length of run are important factors in efficient time and motion operations. Where two or more movers are used, main aisles should be twice the width of moving equipment with load plus clearance, to allow passing. Aisle allowances have to be based on the size of the lifting equipment. Basic allowance can be obtained by using Figure 2.4.1 and the subsequent formulae.

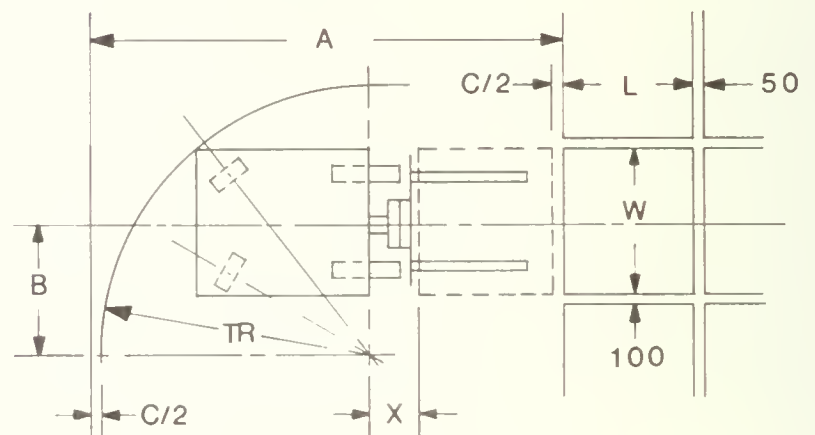

Figure 2.4.1 Aisle width allowance for fork trucks. Dimensions are in millimeters.

Explanation of symbols used in Figure 2.4.1

- A = aisle width
- B = distance from center line of truck to center line of point about which truck can turn when steering wheels are fully turned.
- Tr = turning radius
- L = length of load
- W = width of load
- C = clearance (usually set at 150 mm)
- X = distance from center line of drive axle to face of fork.

For $W < 2B$

$$A = Tr + L + C + X \quad (1)$$

For $W > 2B$

$$A = Tr + (X + L)^2 + \frac{(W - B)^2}{2} + C \quad (2)$$

- Floor conditions, for example, wood, concrete, asphalt, etc. This may limit the loads that can be carried or stacked if floor is uneven and rough, fork trucks or other lifting equipment may be unbalanced and difficult to control.
- The floor bearing load and the most economical and convenient pattern of spacing loads between columns should be considered.

(b) Transportation equipment

- Fork trucks or hand-operated lift trucks for horizontal and limited vertical movement. Hand-operated lift trucks require pallets with open ends through which the forks, which are supported on the ends by wheels, can move.
- Elevators for vertical movement. The elevator may limit the pallet size and load.
- Cranes using slings to handle dock-type pallets.

(c) Pallet requirements

- Area method:

$$N_p = \frac{A_s E N_t}{100 A_p} \quad (3)$$

where

N_p = number of pallets,

A_s = area of storage, m^2 or (ft^2) ,

E = percentage of floor space utilized by pallets, for example, 60-80%,

N_t = number of tiers permitted by the ceiling height,

A_p = area of pallets m^2 or (ft^2) .

- Weight method: Estimate the total weight of material to be moved or stored and divide by the net weight of a unit load. Add 10-20% for the empty pallet storage, partially loaded pallets, and pallets in transit.

- Unit method: In the storage of bulk commodities, peak inventory figures can be divided by the number of units loaded per pallet.

4. Cost of Palletization: $C = D + I + T_i + M + F$

where:

C = cost per pallet per year

Depreciation $D = \frac{\text{initial cost per pallet}}{\text{expected useful life}}$

Average interest I charge per pallet

Insurance and taxes T_i per pallet.

Maintenance $M = \frac{\text{maintenance cost per year}}{\text{number of pallets}}$

Freight cost per pallet $F = \frac{N_{tr} W_t D_i F_r}{N_p}$

where: N_{tr} = Number of trips

W_t = pallet weight

D_i = $\frac{\text{average distance}}{\text{trip}}$

F_r = $\frac{\text{freight rate}}{\text{weight x distance}}$

N_p = number of pallets

5. Pallet selection

- (a) Pallet size selection will be influenced by several factors that should be carefully considered for each application. The American National Standards Institute have adapted the following sizes as standard.

Rectangular (in. X in.)		Square (in. X in.)	
R-1	24 X 32	S-1	36 X 36
R-2	32 X 40	S-2	42 X 42
R-3	36 X 42	S-3	48 X 48
R-4	32 X 48		
R-5	36 X 48		
R-6	40 X 48		
R-7	48 X 60		
R-8	48 X 72		
R-9	88 X 108		

At the time of preparing this revision (1976), a metric standard had not yet been adopted.

The most widely used wood pallet has a surface area of 40 X 48 in. and a height of approximately 6 in. Surface dimensions are designated as length X width, the width referring to the dimension parallel to the top of the deck boards. The surface dimensions are significant, because 2 pallet widths of 48 in. make up the maximum allowable width of 96 in. on flat deck highway trucks. To allow stacking inside closed highway trucks with racks 84 to 88 in. wide the pallets will need to be of the double-entry type to allow fork lift handling to place them side by side (Figure 2.4.2). Refrigerated railway cars are about 99 in. wide and permit 2 pallet widths of 48 in. It is apparent that double-entry pallets are necessary when the same pallet is used for both closed trucks and railroad cars.

- (b) The size of the item to be palletized is theoretically variable but is usually fixed at the time the palletization problem arises.
- (c) Building shape will have some influence as discussed previously in part 2.4.2.2. 3(a)

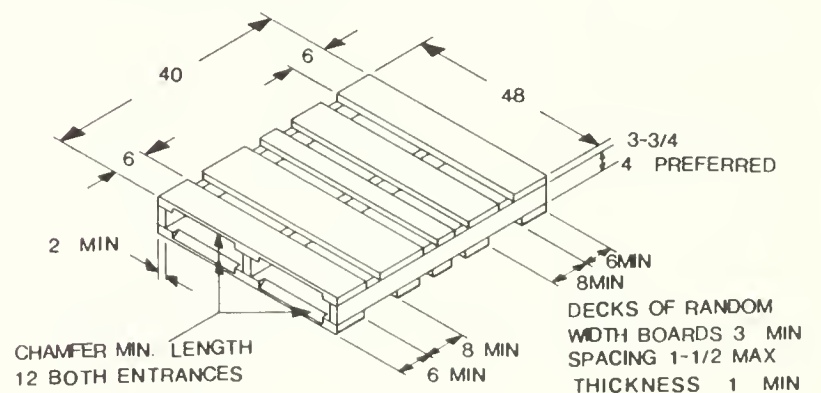

Figure 2.4.2 Double-entry all-purpose pallet. Dimensions are in inches.

2.4.2.3 Pallet Design and Selection

The most important factor in pallet design is the relationship of initial cost to durability. A pallet that is used for a short time, or which is handled infrequently, can be constructed of inexpensive materials.

1. Use: if palletized items are distributed to a non-captive destination then the cost of collecting and returning pallets may suggest that expendable pallets be used. If the distribution is to a limited number of destinations, then the return of pallets for reuse is feasible. Apple (2) indicated that for the late 1960's the cost of reusable pallets was about \$1 per year. The most economical system then is likely to employ reusable and durable pallets.
2. Durability: Steel pallets used on regular and frequent basis can be justified on economic grounds because of

their very low maintenance cost. If pallets are stored in open areas warping will occur unless steel or heavy wood construction is used. Generally the more durable the pallet the heavier it will be. Unless all pallet movement can be made by fork truck, two men may be required to move these heavier pallets. Durability of wooden pallets can be improved: by using spiral nails or common nails long enough to be clinched; by treating with wood preservative; by avoiding the use of wood with loose knots, pitch streaks and dry rot; and by the proper methods of construction to create either one-way or double entry of fork lifts. Figures 2.4.2 to 2.4.4 illustrate recommended construction methods for wooden pallets.

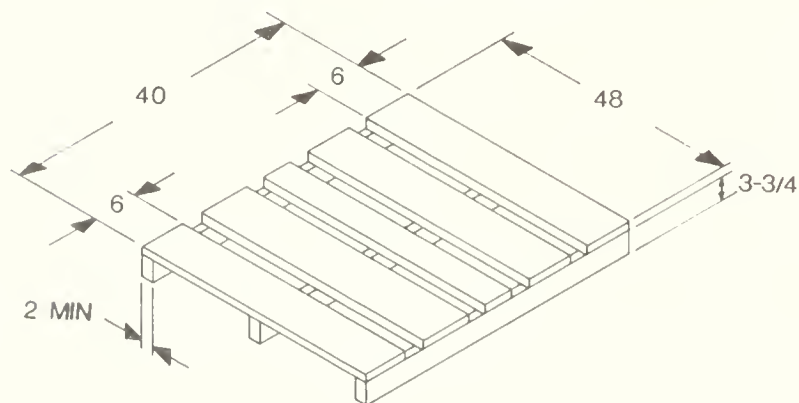

Figure 2.4.3 One-way entry pallet. Dimensions are in inches.

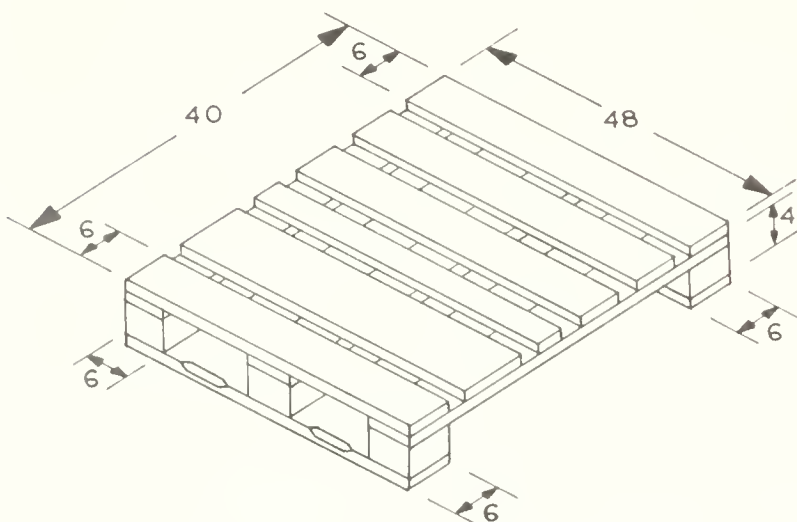

Figure 2.4.4 Double-entry pallet. Dimensions are in inches.

3. **Material:** A wide variety of materials have been used for constructing pallets. Fibreboard or masonite nailed to wooden blocks at the corners and center of the pallet can be used for expendable pallets. Most soft woods except cedar have proven acceptable. More durable pallets are fabricated from a combination steel frame and wooden deck. Other choices are wire mesh, wire mesh baskets, and corrugated aluminum. For heavy duty, corrugated steel is used.

The double-entry pallet gives more flexibility in fork-lift handling onto transport vehicles and into and out of storage. Choice of the double-entry pallet is recommended for handling agricultural produce.

Pallet handling of fruit and vegetables from field to processing plant may be subjected to chemical and thermal treatments such as contact with acids, caustic soda and live steam.

Wooden pallets have the advantage of low initial and maintenance costs. Repairs are easy to make. Loads can

easily be secured to the pallet. Such pallets are noncorrosive.

Metal pallets require fewer repairs than wooden pallets and are easy to clean. Overall height can be reduced about 50 mm. There is no fire hazard. Moisture is not absorbed, so there is no weight gain in a moist environment. Pallet life is about 50 times greater than for wooden pallets and there will be some salvage value when further repair becomes impractical. Therefore metal pallets can be economical if the pallet is to be used frequently throughout the year.

4. **Handling methods:** Often the most effective means of handling non-free-flowing material is on pallets, which in turn can be handled by fork trucks, fork-equipped tractors, trailers, cranes or hoists, and conveyors.

Suitable conveyors for moving pallet loads are chain or flat-belt conveyors. These units are discussed in Section 2.1. Roller conveyors are also suitable for moving pallets over fixed routes. Types of roller conveyors are discussed in Section 2.4.6.1. Fork trucks and other mobile equipment are described in Section 2.4.4.

Pallets can be handled by sling and hoist. This method is useful for field or orchard loading to the truck bed and off-loading at a central warehouse or processing plant. Figure 2.4.2 illustrates a pallet design compatible with sling loading since the bottom deck boards prevent slipping of the sling. However, if the pallet is to be used regularly with a hoist, the top boards should overhang approximately 100 mm so the bars of a sling can be easily positioned under the overhang. This gives faster handling. Because stress is greater on the top boards, nails should be long enough to be clinched.

5. **Pallet stacking:** If palletized material is not held in storage then the handling of single pallets may be justified. Stacking of pallets must be considered if short-or long-term storage of palletized items is to be used. The pallet design shown in Figure 2.4.3 is not recommended for pallet stacking since the pallet load is transferred over a relatively small area of the products below. Unless the palletized items can resist crushing, pallet designs such as shown in Figure 2.4.2 should be used. Alternatively, pallet racks can be built to store single pallets; with this arrangement pallets can be removed from the bottom without disturbing pallets above. This can increase the useful storage area up to 40% or more in addition to providing more flexible handling. When not in use, pallet designs as shown in Figure 2.4.3 and 2.4.4 can be nested into almost one-half the volume required by the double-decked pallet.

2.4.2.4 Construction of Pallets

Pallets may be constructed from a variety of materials, but metal and wood are most commonly used. Metal pallets are manufactured by welding or bolting pressed or cut metal forms. Some pallets are available that consist of one piece of metal pressed in the desired shape. Metal pallets have limited use in agriculture because they are difficult to fabricate on the farm and have a high initial cost, therefore only wood pallet construction will be discussed in detail.

1. **Selection of lumber:** Lumber free from decay, wane, bark, knot holes, loose knots, excessive deformation, and compression wood should be used. Lumber with knots or clusters of knots which extend across more than one-third of the board or which interfere with nailing should not be used. Crossgrain should not exceed 1 to 10. Lumber for

pallets has been arranged into three groups based on their strength, workability and resistance to traffic hazards. Group A are the least resistant, and group C are the most resistant to traffic hazards. Some examples of the 3 groups are:

Group A: Alpine fir, Manitoba maple, spruce, pines, cottonwood, hemlock.

Group B: Douglas fir, larches, poplar, ash, elm.

Group C: Birch (yellow), hickory, hard maple (black and sugar), oak.

The species used for making pallets must be based on the strength required in the pallet and the availability of lumber at a competitive price.

2. *Structural design:* A pallet may be subjected to either concentrated or uniformly distributed loads. Heebink (6) took the average load capacity (obtained from equations) for a concentrated load and for a uniformly loaded simply-supported beam. From this, he developed the design equation:

$$P = \frac{bd^2 f}{s} \quad (4)$$

where

P = load carrying capacity of deck boards

b = width of deck boards measured parallel to stringer (beam width)

d = thickness of deck boards

s = clear span between stringers

f = lumber basic stress for pallets (see Table 2.4.1)

Since the span considered is only half the width of the pallet the result is doubled for the entire pallet load capacity:

$$W = \frac{2bd^2 f}{s} \quad (5)$$

where

W = total load capacity of the pallet

TABLE 2.4.1 Division of Common Species of Wood Into Three Strength Classes

Species and Class	Green Modulus of Rapture		Specific Gravity	Basic Stress for Pallets	
	psi	MPa		psi	Mpa
Class A					
Willow	3,800	26.2	0.36	—	—
Cedar	4,200	30.0	0.36	1,320	9.1
Spruce	4,500	31.0	0.36	1,320	9.1
Buckeye	4,800	33.1	0.33	—	—
Cottonwood	4,800	33.1	0.35	1,320	9.1
Fir (true fir)	4,900	33.8	0.36	1,560	10.6
Pine (except southern yellow)	4,900	33.8	0.38	1,560	10.6
Basswood	5,000	34.5	0.32	—	—
Aspen	5,100	35.2	0.35	1,560	10.6
Hemlock	6,100	42.1	0.38	1,920	13.2
Redwood	7,500	51.7	0.38	2,100	14.5
Class B					
Chestnut	5,600	38.6	0.40	—	—
Soft maple	5,800	40.0	0.44	—	—
Yellow poplar	6,000	41.4	0.40	1,740	12.0
Ash (except white)	6,000	41.4	0.49	1,740	12.0
Douglas fir (except coast type)	6,400	44.1	0.42	1,920	13.2
Sycamore	6,500	44.8	0.49	—	—
Hackberry	6,500	44.8	0.42	—	—
Cypress	6,600	45.5	0.46	2,280	15.7
Magnolia	6,800	46.9	0.46	—	—
Tupelo	7,000	48.3	0.46	1,920	13.2
Sweetgum	7,100	49.0	0.46	1,920	13.2
Tamarack	7,200	49.6	0.49	2,100	14.5
Soft elm	7,200	49.6	0.47	1,920	13.2
Southern yellow pine	7,300	50.3	0.51	2,640	18.2
Douglas fir (coast type)	7,600	52.4	0.45	2,640	18.2
Western larch	8,200	56.5	0.51	2,640	18.2
Class C					
Birch	6,400	44.1	0.55	2,640	18.2
Oak	6,900	47.6	0.58	2,460	17.0
Hard maple	7,700	53.1	0.52	2,640	18.2
Beech	8,600	59.3	0.56	2,640	18.2
Pecan	9,100	62.7	0.59	3,360	23.2
Rock elm	9,500	65.5	0.57	2,640	18.2
White ash	9,600	66.2	0.55	2,460	17.0
Hickory	10,500	72.4	0.64	3,360	23.2

From: Heebink (6)

Since knots are allowed up to $1/3$ of the width of the board, the effective board width is $2/3$; and since the spacing between boards is up to $1/4$ of the pallet deck length the effective board width is $3/4$ of the deck length. The product $(2/3)(3/4) = 1/2$ is the reduction factor to be applied to the beam width. The width of the effective beam (b) expressed in terms of the pallet deck length L becomes:

$$b = \frac{L}{2} \quad (6)$$

The total load capacity now becomes:

$$\frac{Ld^2f}{s} \quad (7)$$

3. *Construction:* The construction and layout of the decks depend greatly on the materials carried. The specifications of the U.S. Navy state that the all-purpose pallet with three stringers should have the deck board spacings between 25 and 40 mm (21). The boards can be of random widths, but should not be less than 75 mm. The recommended minimum width for edge boards is 150 mm. The outside edges of the edge boards are to be chamfered on both decks to permit entry of lift forks. The minimum length of the chamfer should be 300 mm.

Double-entry pallets (Figure 2.4.4) should have 200 mm clearance slots to allow fork entry. The spacing of the slots should be located to accommodate the fork lifts available.

4. *Fasteners:* Fasteners are the parts contributing most to ultimate strength of the finished pallets. Several fasteners and fastening methods have been developed. An expendable pallet does not require the more expensive fasteners as it has only a relatively short life. Recommended fasteners are:

- drive screw nail (recommended by Wooden Pallet Manufacturers' Association, June 1962);
- cement coated nails;
- carriage bolts;
- glue and dowel construction; and
- wire strappings.

Nails should be driven through the deck boards into the stringer towards a hole drilled across its width. The center line of the drilled hole is parallel to the direction of the deck board. The nail when fully driven has its end protruding into the hole. All nails are driven into the hole, their ends clinched and the hole filled with a dowel to prevent nail withdrawal (5).

2.4.2.5 Preservatives

Since the cost of rebuilding good quality pallets is often excessive it may be economic to apply a preservative. The application is especially warranted if pallets are to be kept under severe atmospheric conditions, such as cold rooms and other moist places.

1. *Wood pallets:* Wood pallets should be treated with a preservative having the following characteristics (11):

- water repellent;
- prevents grain raising and checking;
- does not break down readily in sunlight;
- is non-toxic to humans and animals;
- does not impart flavors to the fruit or vegetables;
- is suitable for dip treatment;
- relatively inexpensive;
- fungicidal; and
- non-staining.

The most promising preservatives are wood sealers dissolved in petroleum solvent. Many of the available

products are a copper-8-quinolinolate compound to which a coloring pigment dissolved in a petroleum solvent can be added (11). One product that has given promising results is a pigmented alkyd base available in various colors. The preservatives are easy to apply by dipping. Copper-8-quinolinolate is the only preservative approved by the U.S. Department of Food and Drug Administration.

2. *Metal pallets:* Some non-corrosive metals such as aluminum and stainless steel do not have to be protected. Other metal pallets may be painted or coated with a non-corrosive metal or spray. This treatment is more expensive than dip treatment of wood pallets, but the added expense is good insurance on the investment in metal pallets.

2.4.2.6 Pallet Loading

Since haphazard loading of pallets can lead to slow loading performance, waste of storage space and increased danger of injury to workmen or products, a standard loading pattern must be adopted. The loading pattern should provide some interlocking of individual items on the pallet.

1. *Load arrangement:* There are two basic methods for establishing the maximum pallet load.

(a) *Size of package or article:* The fact that a regular object has rectangular dimensions considerably simplifies the final resolution of the pallet pattern selection. Chart-type techniques have been developed which remove the trial and error procedures. The matrix of container sizes and a chart of pallet patterns for a common pallet size is shown in Figures 2.4.5 to 2.4.7 (2).

(b) *Weight of package or article:* The pallet loading can be based on the total allowable weight that can be carried by the pallets. The load capacity should, however, be based on structural calculations which should not be exceeded — see 2.4.2.4 (2).

2. *Securing loads:* Even if all precautions are taken in loading a pallet, the load may not be a strong bonded unit. This weakness can be overcome by using securing agents such as:

- wire or steel strapping;
- gummed or adhesive tapes;
- glue with a high shear strength and a low tensile strength used on fibreboard or cartons; or
- hold-down clamps on fork-lift equipment for securing loads during transit (see 2.4.4.1).

3. *Building the load on the pallet*

(a) Manual handling may be the easiest, most efficient least expensive method to move materials. Items to consider are:

- Material characteristics such as small, light-weight, fragile, expensive and safe-to-handle items.
- Quantity, such as small in number, or low volume and single items.
- Movement characteristics such as short distance, infrequent moves, low rate and non-uniform rate and manoeuvring and positioning.
- Pallet loading such as one or more operators arranging desired pattern and possibly using a jig to assure alignment.

(b) Semi-mechanized method of building the load. An operator accepts items for palletizing and arranges them into the required pallet pattern. A machine then transfers the layer to a pallet and the operator repeats

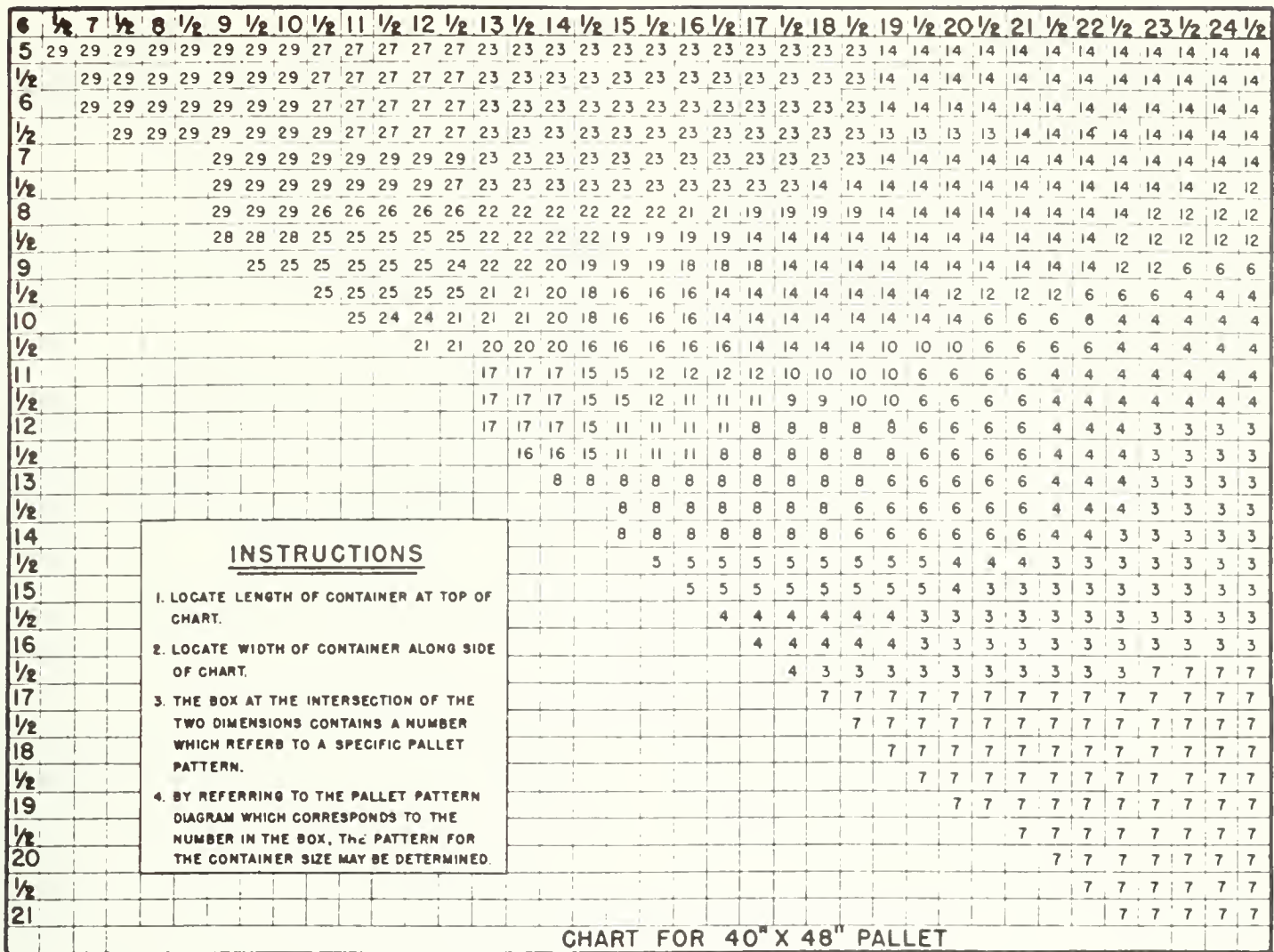

Figure 2.4.5 Container size matrix. From: J.M. Apple, Material Handling System Design, 1972.

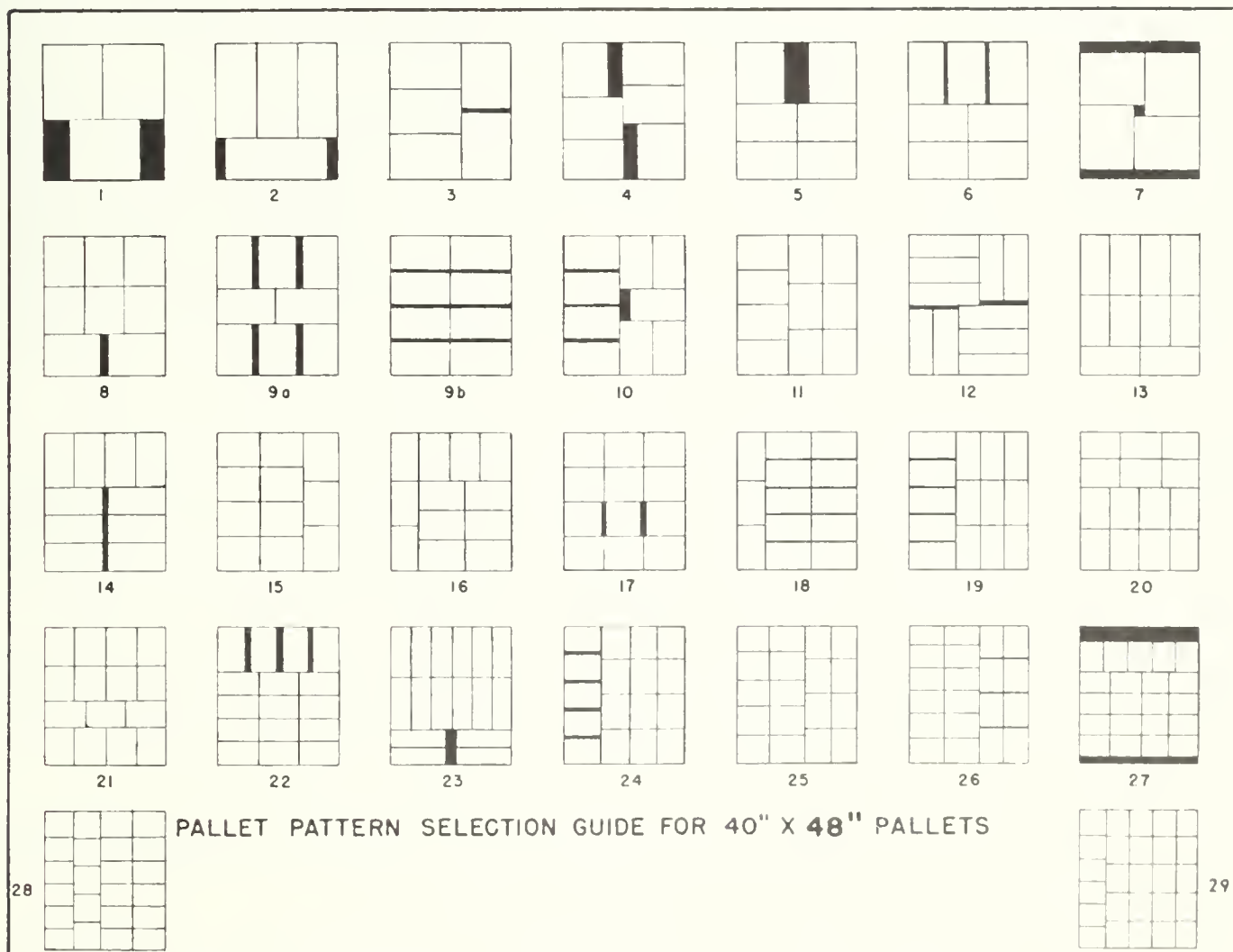

Figure 2.4.6 Pallet pattern selection guide. From: J.M. Apple, Material Handling System Design, 1972.

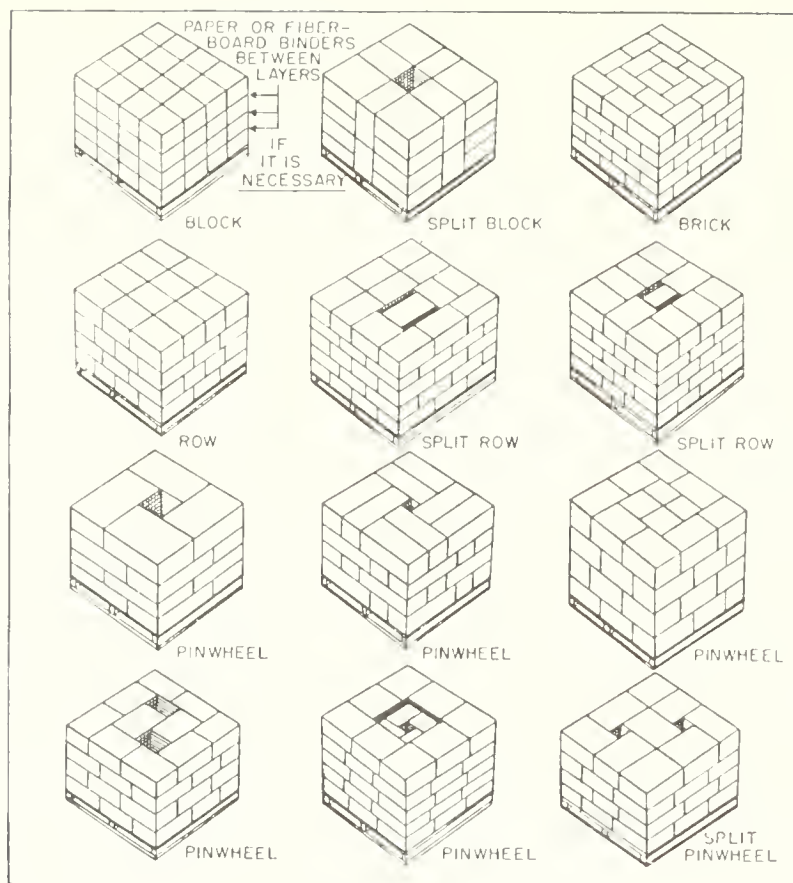

Figure 2.4.7 Building pallet loads. From: J.M. Apple, Material Handling System Design, 1972.

the procedure. This method is suitable to high-rate loading and allows for different pallet patterns and pallet sizes.

- (c) Automatic palletizing uses a machine that accepts cartons, bags, drums etc., arranges them into layers and places each layer on a pallet. It then discharges the complete unit for removal by conveyor or fork-lift truck.
- (d) Guidelines to developing unit loads are:
- Develop a configuration and unit load type in consultation with supplier of packages or cartons.
 - Determine the physical properties of the material to be handled.
 - If more than 15 items are required to build a layer the items should be further containerized.
 - Do not stack cartons on their sides.
 - Voids should be aligned parallel to the short direction of the pallet.
 - Items should interlock a minimum of 30% for items under 4.5 kg, 20-25% for items under 18 kg and 12-15% for items over 18 kg.

2.4.3 PALLET BINS

Pallet bins are also known as pallet boxes, bin boxes, tote bins, bulk boxes and bulk bins.

Pallet bins are an extension of the palletization program discussed in 2.4.2. The variation comes from the fact that a great number of smaller particles or even fluids are confined to a container fixed on top of a pallet structure.

Pallet bins are used extensively in the fruit and vegetable industry. Harvesting vegetables introduces considerably more diversification since they are more heterogeneous when attempts are made to apply standards to their containers. Pallet bins and wire-bound pallet bins have been used for such items as celery, tomatoes, green

beans, potatoes, cauliflower, broccoli, sweet corn and spinach. The tree-fruit industry led the way in accepting the pallet bin handling system for the largest part of its production in Western Canada (11). This, however, does not imply that pallet bin handling could not be applied to other farm commodities.

Since the growing and handling of fruit involves various farmer cooperative or company-owned packing houses with storage rooms, a standard-sized pallet bin should be used to allow for easy stacking and building of rows.

2.4.3.1 Purpose of Pallet Bin Handling

The handling of certain material in pallet bins has significantly reduced the man hours per unit of harvested product. This gain, however, has created new problems of product damage. Some features of bin pallet handling are:

1. Advantages

- (a) Picking performance is increased.
- (b) Fewer containers result in less accounting.
- (c) Cost of field containers is reduced.
- (d) Lower transport cost in orchard and from orchard to packing house results in substantial savings over and above extra-cost outlay for pallet bin handling equipment.
- (e) Faster moving around storage plant since less tendency to lose loads.
- (f) Storage capacity can be increased. The space occupied by two pallet bins is approximately 20% less than an equivalent amount in bushel boxes on a pallet.
- (g) Better ventilation may be possible in potato storage buildings if pallet bins are used. This is particularly true if potatoes are partially covered with soil due to moist harvesting conditions.

2. Disadvantages

- (a) Cooling and ventilation of pallet bins requires special construction features (11).
- (b) Damage of the product limits the depth to which pallet bins can be filled. Studies for different fruits have resulted in standard bin sizes for the Western Canada tree-fruit industry (11). Depth of bins for other commodities should be based on actual experience.
- (c) Handling of pallet bins cannot be done manually and requires special equipment (see 2.4.4).

2.4.3.2 Planning a Pallet Bin Handling System

Since the pallet bin handling program is an extension of the palletization program, factors discussed in 2.4.2.2 also apply. Factors that apply directly to pallet bins will be discussed here.

1. The recommended pallet bin from the Okanagan Federated Shippers has overall dimensions of 48 x 43 x 24 in. The eastern region bin is 48 x 42 x 24 in. Depending on the type of integral pallet the overall height is 29 to 30 in. (11). The reasons for this design are:

- (a) The length and width are approximately the same as pallets already in use. Rows in storage rooms can be constant width using pallets with loads and pallet bins interchangeably.
- (b) The rectangular bins allow for easy stacking when loaded. This shape also allows for nesting of empties. One bin is placed inside two others arranged with

open sides abutting for a saving of 33% of storage space for empty bins.

- (c) The 43 in. width allows full use of space in refrigerated railway cars and closed highway trucks.
- (d) The 30 in. height allows for easy depositing of fruit produce by pickers. This results in less damage.
- (e) The 24 in. depth was considered the maximum to avoid pressure bruising of McIntosh apples (11).
- (f) The 48 x 24 in. sides allow for economical use of standard plywood sheets. When metric dimensioned plywood becomes available these dimensions will probably be 1200 x 600 mm to allow economical use of 1200 x 2400 mm plywood sheets.

This type of pallet bin has proven successful for handling of apples, Bartlett and Anjou pears. McMechan (11) has found that for the stage of maturity reached during picking of Okanagan peaches the depth in pallet bins must be limited to 10 in. False bottoms to accommodate two layers of peaches in a 24 in. bin have not proven too successful since inversion of the bin during emptying creates a layer of peaches 20 in. deep.

2. Double-entry pallet bins provide the most flexible method of transporting and stacking of bins. Since double-entry allows for free movement of air above and below the produce, the bins require fewer ventilation slots than single-entry pallets. A row of stacked single-entry pallet bins can form a solid wall and interfere with the circulation of cooling air.

Double-entry pallet bins allow for easy pick-up in the orchard. It has been shown however that double-entry pallet bins tend to pick up dirt on the bottom slat and contaminate the produce in the box below.

3. Since the construction cost of pallet bins is usually high, they should be built for durability. Construction features such as diagonally cut corner cants, metal corner brackets and straps, will increase the strength and rigidity of the pallet bin. Additional strength will increase cost but longer life may warrant the extra expenditure. Approximately 3% of new pallet bins require replacement each year. Figures 2.4.8 to 2.4.10 show details of construction for wooden pallet bins.

4. Special equipment is needed for handling pallet bins on the farm, transporting them on the highway, stacking,

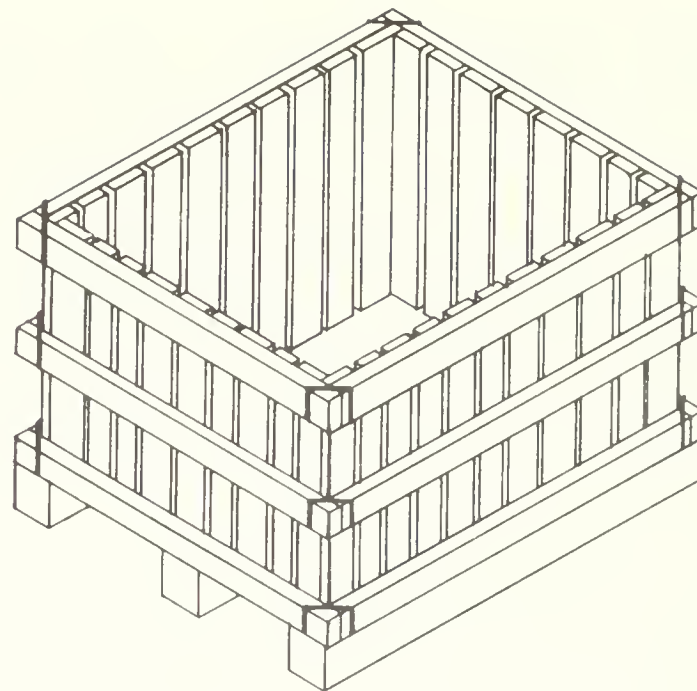

Figure 2.4.9 Pallet bin with corner clamps

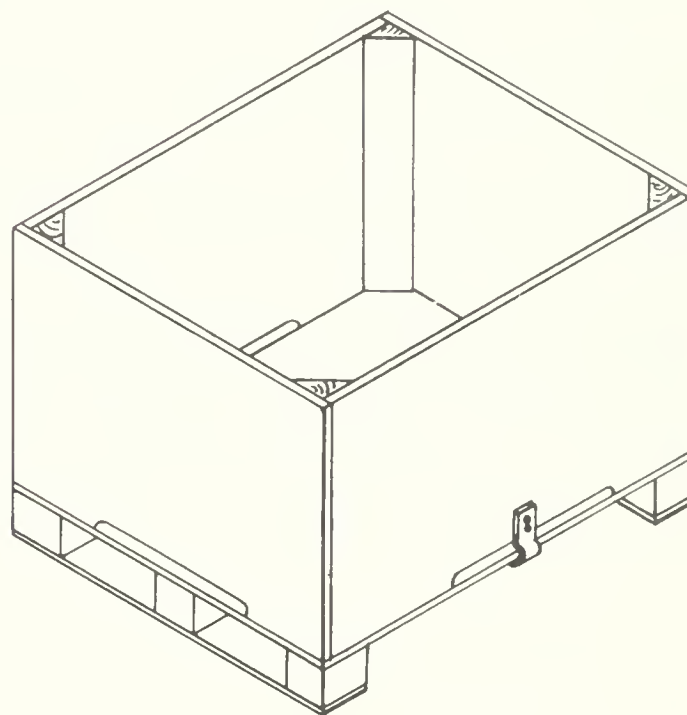

Figure 2.4.10 Plywood pallet bin.

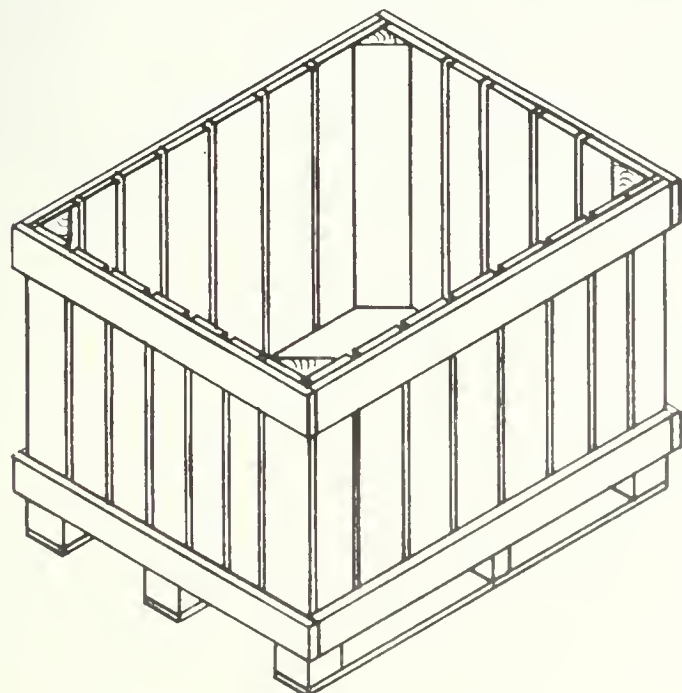

Figure 2.4.8 Pallet bin with corner posts.

handling and emptying them in warehouses or packing plants. Some examples of equipment are:

- front and rear lift attachments for tractors;
- industrial fork lifts;
- trailers;
- sleds;
- flat deck trailers and trucks;
- straddle trailers and trucks; and
- bin tipping and inversion units.

See 2.4.4, 2.4.5 and 2.4.6 for more on the characteristics of this equipment.

2.4.3.3 Construction and Treatment of Pallet Bins

Since pallet bins have come into use, different designs have been developed.

1. *Vertical and horizontal sideboard construction:* Bins with vertical sideboards are rigid, strong and have good

stacking capacity. The boards used are short and can be cut from low grade lumber with very little waste. Horizontal boards, have the advantage that stresses due to bumping and handling are carried to the corners of the bin, but can increase injury to the stored product (7).

The construction of bins with vertical boards varies slightly but the main area remains the same. Vertical side-boards are nailed to horizontal crossmembers attached to the integral pallet. Figure 2.4.8 shows this, with a 4 x 4 in. triangular corner post for strength. Figure 2.4.9 shows metal slips to hold the horizontal stringers.

The boards used in these bins are a full 1 in. thick. If rough-sawn lumber is to be used, the bins should be lined with cardboard liners.

Pallet bins made of small boards invariably need liners after some use because the lumber twists and splits. Liners interfere with ventilation unless slotted. If the pallet bin is to be always used with a liner, the boards can be spaced further apart and the savings made in lumber will offset the cost of liners. Cardboard liners should be wax-coated and fastened in place with large-headed roofing nails.

To prevent bruising in unlined bins the surfaces should be smooth. Boards having sharp edges should be rounded off or bullnosed at a radius equal to the thickness of the board. This edging is especially needed if ventilating slots are cut into the sides or bottom of the bins.

The stringers should be 3 x 4 in. rather than 2 x 4 in. The wider stringers allow for wider spacing of nails when attaching deckboards to the stringer, resulting in a stiffer pallet.

2. *Plywood construction:* The plywood pallet bin is used in the fruit and vegetable industry. The plywood face grain should run parallel to the pallet deck, since the stiffness of a plywood sheet varies with the thickness and the direction of the face grain. The corners are reinforced with diagonally cut 4 x 4 in. dressed lumber, while the bottom and sides are respectively $\frac{3}{4}$ and $\frac{1}{2}$ in. G1S unsanded exterior-grade plywood.

The bottom of a one-way entry pallet bin is supported by two or three full-length 4 x 4 in. stringers; short lengths of 4 x 4 in. blocks support the bottom of a double-entry pallet bin (Figure 2.4.10). Adding a 1 x 4 in. slat to the bottom of the blocks will strengthen the double-entry pallet bin.

To provide interlocking of stacked bins the 1 x 4 in. on double-entry pallet bins can be set in the width of the bin sides. The ends of the 1 x 4 in. are miter-cut to match the diagonally cut corner post of the pallet bin below. This feature can also be added to the one-way entry pallet bins.

The smooth surface of plywood makes it unnecessary to use cardboard liners provided any knot scars are filled. The tight construction achieved with plywood makes it essential to furnish ventilation slots. McMechan recommends a 1 in. slot cut into the sides and ends at floor level most of the way around the bin (11). The slots, however, should not extend over the points at which the lift forks act. The ventilation opening depth is limited to 1 in. or to the radius of the smallest fruit to avoid product damage.

3. *Fasteners:* The fasteners described under pallet construction, 2.4.2.4 (4), apply directly to pallet bin construction. All plywood joints should be glued and nailed. Fasteners should be rustproof and have strong holding capacity. Resorinol resin or moisture-resistant casein glue is recommended. Staggered nailing reduces lumber splitting. Nails, where possible, should be driven

from the inside and clinched on the outside. Some designers and manufacturers of bins use nuts and bolts to tighten the stringer or corner blocks to the plywood deckboard.

4. *Preservatives:* See 2.4.2.5.

2.4.4 LOADING OF UNITIZED CONVEYORS

The basic principle of unitized handling of material is to move, load or unload a number of small items or a quantity of bulk items as a unit load. The unit load may range from a carton for a dozen eggs to boxes which carry several tonnes. Unitized handling refers not only to pallet bins and bulk lots, but also to handling of non-free-flowing material such as manure, hay, straw, soil, etc. Since many farm produce handling devices are available, considerations for selecting equipment are presented here.

This deals primarily with loading equipment, but many items of equipment can also perform other functions. Always consider the possibility of modifying implements to adapt them to other farm chores.

Most implements for farm use are attached to or driven by the farm tractor, and the time required to connect and disconnect the implement must be considered. For instance, moving a quantity of gravel should not involve more than a little time to get the scoop to work. Spending several hours adjusting attachments to do a job that could have been done by hand in 2 hours is uneconomic.

Determine the usefulness versus the capital and operating cost. Consider the labor saved in relation to the cost of light or heavy duty machines.

Some of the various implements that can be classified as loading and handling devices are:

- fork lifts;
- low-lift fork-lift trucks, and tractor attachments;
- belts, chains, and augers;
- portable hoists;
- stationary equipment used for bulk loading;
- front-mounted loaders; and
- rear-mounted loaders.

2.4.4.1 Fork Lift

The development of the fork lift has greatly advanced work in the materials handling field, where it is used to load and unload large unitized conveyors. The fork lift essentially consists of two thin tapered parallel steel prongs held apart by a steel frame at right angles to the prongs. The spacing of the prongs gives proper balancing of a load placed on it cross-wise. Forks are pushed under the load and the complete unit raised by a power source.

The fork length should be approximately 25 mm shorter than the load length to be handled. This will have to be based on the size of pallet used, and emphasizes the desirability of a standard-sized pallet. Short forks tend to spring the boards or bottom of the containers and damage the produce carried. The general purpose 40 x 48 in. pallets require forks 750 mm (30 in.) long.

Since most forks project away from the power unit, the load can tip the vehicle unless it is properly balanced. Some fork-lift units have a loading mast that can be tilted backwards when the load is in place. This shifts the center of gravity and helps stabilize the unit and load when in motion. When travelling over rough terrain a hold-down clamp will steady the load. In orchards, however, high loads with clamps may damage the trees.

The choice of tires for the fork lift is very important. Small hard tires are recommended if most of the moving is on pavement or smooth floors since they present less rolling resistance and provide a more stable base for elevating loads in a warehouse. The rough terrain of farm yards, orchards, etc, require pneumatic tires. These can also be used on hard floors, and are therefore best for farm use. The pneumatic-tired lift will require more room for loading and unloading.

Some equipment for operating fork lifts are:

1. *Mechanical fork lifts* (hand-operated non-riding lift trucks)

(a) The main characteristics are:

- low initial cost
- low maintenance costs
- lightweight for easier manoeuvring
- compact design
- simple operation

(b) Applications are:

- loading and unloading carriers
- supplemental units for powered fork-lift trucks
- over moderate distances of 15-60 m (50-200 ft)
- for intermittent, low frequency use
- for manoeuvring in tight quarters and narrow aisles

(c) Disadvantages are:

- manual effort is required
- cornering on narrow aisles is a problem
- bumpy rides due to small wheels

Figure 2.4.11 illustrates a typical unit for warehouse and packing house work.



Figure 2.4.11 Low-lift pallet lift. Useful for moving one to two bins in a packing house.

2. *Fork-lift trucks:* Industrial fork-lift trucks have been used to a large extent in the fruit industry. Their use is especially warranted for high stacking and large volumes. Industrial fork lifts are heavy and usually have small hard rubber tires or pneumatic tires. Their purpose is short-distance transport since no return load is carried. Fork-lift trucks allow loads to be moved rapidly and gently in confined spaces such as storage and cooling rooms.

The capacity of fork-lift trucks is usually based on a homogeneous load in a 1200 mm (48 in.) cube. The lift is

rated in pounds at a given distance from the center of the front wheels (see Figure 2.4.12). Standard truck ratings are:

- 1,000 lb @ 24 in.
- 2,000 lb @ 24 in.
- 4,000 lb @ 24 in.
- 6,000 lb @ 24 in.

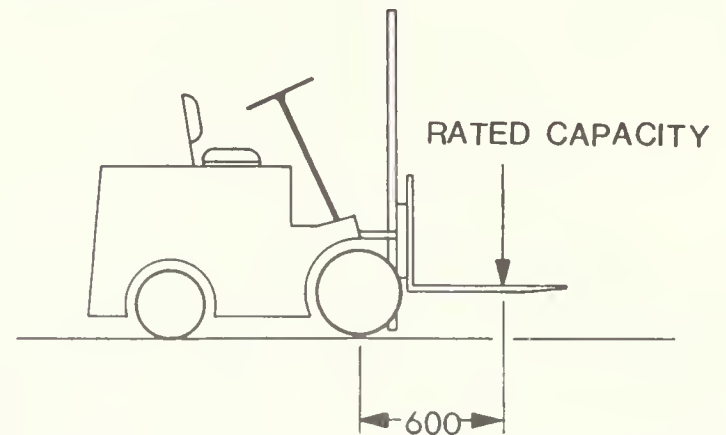

Figure 2.4.12 Criteria for capacity ratings of fork lift trucks. Dimensions in millimeters.

For farm and warehouse use, common truck capacities are 450 to 900 kg (1,000 to 2,000 lb), and rarely exceed 2700 kg (6,000 lb) (5).

(a) Characteristics of fork-lift trucks are:

- They are self-powered by gasoline, diesel, L.P. gas engine or batteries (no power lines).
- The mast may be tilted forward or backward to facilitate loading and unloading.
- The operator may sit or stand in the center or back of the truck.
- Wheels and tires are available for a wide variety of floor or roadway conditions.
- Electric and L.P. types are especially useful in enclosed buildings.

(b) Applications are:

- Lifting, lowering, stacking, unstacking, loading and unloading.
- Over variable and flexible paths.
- For medium or large unit loads.
- For uniform shaped loads.
- For intermittent moves.

(c) Disadvantages are:

- Skid, pallet or pallet boxes are required.
- Suitable running surfaces are required.
- Gas units are noisy and produce harmful CO while electric units are slower and have a high initial cost.
- Skilled operator is required.
- Moves over 90 m are uneconomic.
- Travel speeds are limited to 10-16 km/h.
- Lift speed is limited to 0.4 m/s.
- Can only be used on limited grades.
- Lift heights are limited to 6 m.

Figure 2.4.13 shows a typical electric fork lift handling bulk bins.

3. *Tractor attachments:* The farm tractor can also be used as a lift truck. Lifting and tilting fork-lift attachments are available for both the front and rear of practically every make of tractor. These attachments vary greatly in price and practicability; the choice depends primarily on cost, hauling distance, condition of terrain and plant facilities.



Figure 2.4.13 Electric fork lift. Useful for loading, unloading, transporting and stacking bins in a packing house.

- (a) Fork attachments for three-point hydraulic hitch: Tractors so equipped can be inexpensively changed to a simple fork lifting unit, with lifting capacity from 450 to 900 kg for a height of 450 mm. Pallet bins can be moved from the orchard to the loading area and onto trucks if the truck is placed at a loading dock or pit. The lift limits loading to one or two layers of bins or pallets

depending on the design of the attachment. One man with this rear-lift tractor unit can haul from eight to 12 bins per hour from the orchard to the unloading area (McMechan 11). Figures 2.4.14 to 2.4.16 show three-point hitch attachments to convert a tractor to fork-lift operation for bulk bin handling.

- (b) Fork attachments for buck rakes (hay loaders): Forks may be mounted on a front-mounted loader with a 540 to 900 kg lifting capacity. The operation is not smooth, but it can be used to raise pallets a height of 3 to 3.6 m. For handling pallet bins a third cylinder is recommended to let the operator keep the forks level during the loading cycle. The difficulty is that operation is rough and the visibility for the driver is poor. For sustained heavy use, oversized front tires, front-end reinforcement and power steering may be necessary. Figure 2.4.17 shows an example of this type of fork lift.
- (c) Fork-lift attachments for tractors: Lift attachments similar to fork-lift trucks can be attached to tractors at a reasonable cost. These units can be custom built or purchased ready-made; they are fitted in the rear of the tractor or sometimes in the front. The mounting improves visibility but makes loading and stacking more difficult. These units have a capacity up to 1 tonne and can lift to the same height as a fork-lift truck. Some tractors have been converted to carry three full bins or pallets at one time. This may be justified if hauling distance warrants it. One tractor equipped in this manner can haul 14 bins per hour from orchard to packing house over a distance of 0.8 - 1.2 km (11).

Examples of these units are shown in Figures 2.4.15 and 2.4.16.

4. *Walkie trucks*: These units are useful in a packing house. One type has basically the same structure as a fork-lift truck except that the driver walks; the other type has similar construction to the mechanical fork lift with straddle legs or outriggers. Controls are on the steering handle. The lift mast does not tilt, hence they are stable



Figure 2.4.14 Front-mounted bin stacker and rear-mounted three-point hitch transporter for tree to tree handling of bins. Rear-mounted unit lifts 0.7t up to 0.4 m. Courtesy: Edwards Equipment Co., Yakima, Wa.



Figure 2.4.15 Rear-mounted bin stacker, 1 tonne capacity, lift heights available from 1m to 2.7m. Courtesy: Edwards Equipment Co., Yakima, Wa.



Figure 2.4.16 Hydraulic rear-mounted fork lift with hold down attachment. Will lift 1.8 t from 1.5 to 3.6 m. Courtesy: Edwards Equipment Co., Yakima, Wa.

only on smooth surfaces. Power can be supplied by either batteries or internal combustion engine.

- (a) Characteristics of walkie trucks are:
- Smaller, lighter and slower than rider types.
 - Usually battery powered.
 - Lower cost.
 - Dependable.

- (b) Applications are:
- Light loads.
 - Distances under 75 m.
 - Operating in congested areas.
 - For occasional use.

- (c) Disadvantages are:
- Slow operation
 - Capacities are 1 to 2 t.
 - Low lifts up to 4 m.

5. *Four-wheel hand truck:* This unit is a rectangular load-carrying platform with 4 or 6 wheels for manual pushing.

- (a) The main characteristics of wheeled hand trucks are versatility and low cost.

- (b) The main uses for wheeled hand trucks are:
- Manual handling of large loads.
 - For low frequency moves.
 - For low volume movement.
 - For movement over short distances.
 - For handling awkward shapes.

- (c) The main disadvantages are:
- Requires manpower.
 - Capacity is limited to about 2 t.
 - Slow.

6. *Pallet dolly:* These are small low platform carriers with rollers or castors. Like the wheeled hand truck, the pallet dolly is versatile, durable and inexpensive. Capacity is 1-1.5 t.

- (a) Applications are:
- Low volumes.
 - Movement over short distances.
 - For a wide variety of loads.

- (b) Disadvantages are:
- A good floor is needed.
 - Requires manpower to move loads.
 - Travel distance is limited.

7. *Estimated time for selecting equipment and labor needed:*

Walking	4.8 km/h
	0.67 s/m
Fork lift:	
- laden	4.0 km/h
	0.86 s/m
- unladen	8.0 km/h
	0.43 s/m
- pick up/	45 s/occurrence
set down	0.75 min/occurrence
Hand lift truck:	
- laden (one pallet)	1.18 s/m
- unladen	0.78 s/m
- pick up/	30 s/occurrence
set down	0.5 min/occurrence

2.4.4.2 Belts and Chains

Elevating chains and conveyor belts are often used to transfer unitized loads into trucks or buildings. The basic structure of this equipment is discussed in 2.1.

2.4.4.3 Tractor-mounted Front End Loaders

One of the most versatile bulk material handling devices is the tractor-mounted front-end loader. The loading unit, of which there are many variations, is supported by a metal frame. The frame is supported or hinged on either the rear axle housing or above the hood of the tractor for maximum stability. A point near the middle or front of the frame is connected to hydraulic cylinders which supply the lifting force.

The hydraulic pump used for a loader should have a flow divider. This splits the oil flow evenly between the two lifting cylinders, giving equal travel to both sides of the loader frame to prevent wracking (14).

1. *Implement support:* Implements are frequently pivoted so that they dump the load when released but return to a locked position by gravity when empty (14). While the implement is loaded and transported a spring-loaded catch holds it until released at the required height and position. Special linkages are also available that will allow the implement to take up certain loading positions if sticky material is handled. Hydraulically operated dumping mechanisms can be obtained if dumping is required at a controlled rate.

2. *Length of loader:* The length of the loading arms depends on the lift height and the maximum reach expected. The overhang should reach to the middle of the truck or trailer to be loaded. In the case of manure spreaders, 0.6 m (2 ft) appears adequate (14). The overhang for a high truck should allow for both height and reach.

3. *Capacities:* Capacities of front-mounted loaders cannot be based only on the capabilities of the hydraulic cylinders. Simple mechanics show that a 450 kg load on a front-mounted loader can overload the front wheels of the tractor. A counterweight behind the rear wheels may be necessary to reduce the front wheel loads to conform to the tire specifications. For safety when travelling the load bucket should be kept close to the tractor.

In addition to their loading capacities most loaders have a high breakaway force. This force is especially useful when loading compacted or fibrous material. This occurs because the length of the moment arm (measured perpendicularly from the hydraulic lift cylinder center line to the pivot point nearest to steering wheel) is much greater when the attachment is down than when fully raised (1). See figure 2.4.18.

4. *Performance:* The performance of a front-mounted loader is rather difficult to predict. A large powerful tractor with loader may perform very poorly if the travelling distance is long and the operator inexperienced. Any performance must be based on actual observation and on:

- compactness of material loaded;
- size of particles picked up;
- possibility of heaping or topping of load;
- condition of ground being travelled;
- distance load being transported;
- loading procedure; and
- handling of tractor.



Figure 2.4.17 Fork lift attachment for front-end loader. Courtesy: John Deere Ltd.

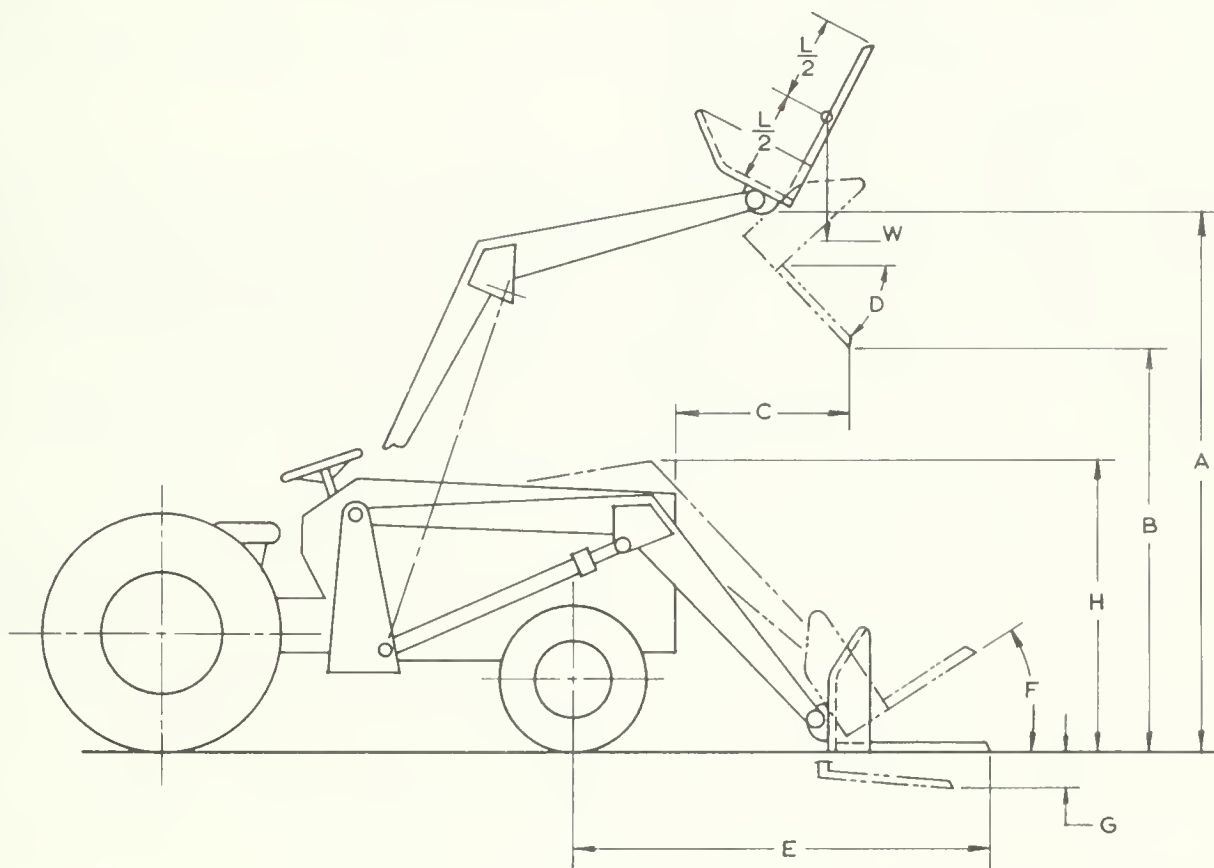

Figure 2.4.18 Front-end agricultural loader dimensional specifications.

- A. Maximum lift height
- B. Clearance with attachment dumped
- C. Reach at maximum height
- D. Maximum dump angle
- E. Reach with attachment on the ground
- F. Attachment roll-back angle
- G. Digging depth
- H. Overall height in carry position
- L. Length of attachment
- W. Lift capacity to full height

5. Front-mounted loader attachments: A large variety of attachments can be adapted to fit a front-mounted loader. This adaptability spreads the loader purchase cost over a wider range of jobs.

Attachments are often highly specialized, such as:

- manure loaders;
- silage loaders;
- grapple loaders for bales;
- grapple loaders for bulk hay or straw;
- scoops for gravel, snow and wet manure;
- hoists;
- fork-lift attachments; and
- root crop buckets.

(a) Silage and manure loaders: Silage-wagons are loaded with fresh silage in the field by a pneumatic blower that is part of the silage cutter. A front-end loader with a silage or manure fork can be used to remove silage from a horizontal silo. These should be used on tractors rated at 30 to 55 kW (40 to 75 hp). Lifting capacities will be up to 1300 kg to a height of 3.2 m. Figure 2.4.19 shows a typical tractor-mounted unit. Either the tractor hydraulics or a separate PTO-driven hydraulic pump may be used. Figure 2.4.20 shows a special power unit for front-mounted loader attachments; typical power ratings are 10 to 45 kW (13 to 60 hp).

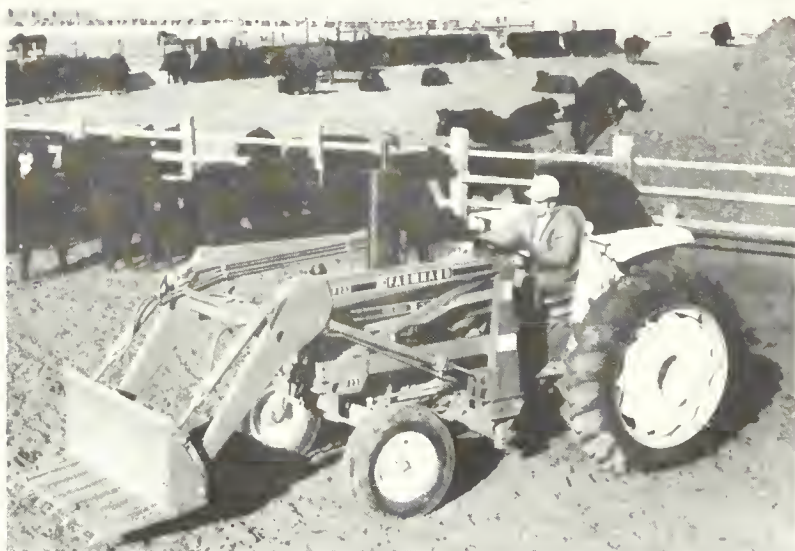

Figure 2.4.19 Typical front-mounted silage or manure fork. Power is supplied by the tractor hydraulics or an auxiliary hydraulic pump. Courtesy: Farmhand Inc., Hopkins, Minn.

- (b) Grapple loader for bales: The loader is a rectangular frame with hydraulically operated grapple hooks, attached to a normal front-mounted loader. The frame width is equal to four bale widths. When the frame is placed on top of the bale the hydraulic grapple hooks dig into eight bales and keep them together as a unit package as seen in Figure 2.4.21. This package can then be loaded on a truck or trailer. The bale loader can also be used to build and unload hay stacks, giving complete mechanical bale handling from field to feed lot. See 2.4.6.3, 3(b) for operational characteristics.
- (c) Gravel and snow scoop: Scoops for handling gravel, sand or snow vary only in size based on the weight of material to be carried and the capacity of the tractor.

The snow scoop can also be used for handling gravel or sloppy manure if loads are kept light.

- (d) Hoists: An extension framework of tubular steel can be attached to a loader; a hook or grapple attachment lets it be used as a hoist or lifting unit. A special grapple attachment has been developed that hooks on to the neck of a bundled sack when loading potatoes. The hoist can also be used for lifting heavy farm machinery.
- (e) Fork-lift attachment: Fork-lift attachments are available for handling pallets or pallet bins, as discussed in 2.4.4.1, 3c and shown in Figure 2.4.17.
- (f) Root crop buckets: Special buckets have been developed to handle such items as sugar beets, turnips, mangels, etc. The difficulty with these scoops is that large amounts of dirt are collected with the produce. Sugar beets especially are often put in large stacks and later reloaded for shipment to the processor.

2.4.4.4 Rear-mounted Loaders

Rear-mounted loaders have several advantages over front-mounted loaders. They distribute weight to the much stronger and better-supported rear axle. In forward travel the operator's vision is not restricted by large loads. Figures 2.4.16 and 2.4.22 show two examples. However, they do have some disadvantages.

Since the loader is at the rear, the operator must turn around to watch the loading. This is very tiring if performed over a long period; a reversible seat and controls helps. A hydrostatic drive option allows the tractor to move during the loading cycle, unlike industrial units that require the tractor to be stationary while loading or digging.

To stabilize the loaded tractor, counterweights are often installed in front of the front axle.

The main advantage for rear-mounted loaders is that buckets, lift forks and other implements can be manoeuvred easily in close quarters. These units can be easily attached and detached (14). The lifting height of rear-mounted loaders may be up to 1.8 m, adequate in most cases for handling pallet loads and pallet bins, as well as for other farm chores.

2.4.5 UNLOADING UNITIZED CONTAINERS

Unitized containers are not always simple to unload.

Unloading devices for farm operations should be chosen for their adaptability to other chores. Base selection on considerations similar to those used to select loading equipment (some loading devices may be used as unloading units). The decision of which to choose should be based on:

- weight of each unit;
- distance unit must be moved;
- number of units to be handled per year;
- change in elevation;
- utilization for other operations; and
- maintenance required.

See also:

Belts and chains	2.1
Augers	2.3
Front-mounted loaders	2.4.4.3
Self-loading carriers	2.4.6.3



Figure 2.4.20 Skid-steer loader for front-mounted bucket, fork or blade. Courtesy: Gehl Company, West Bend, WI.

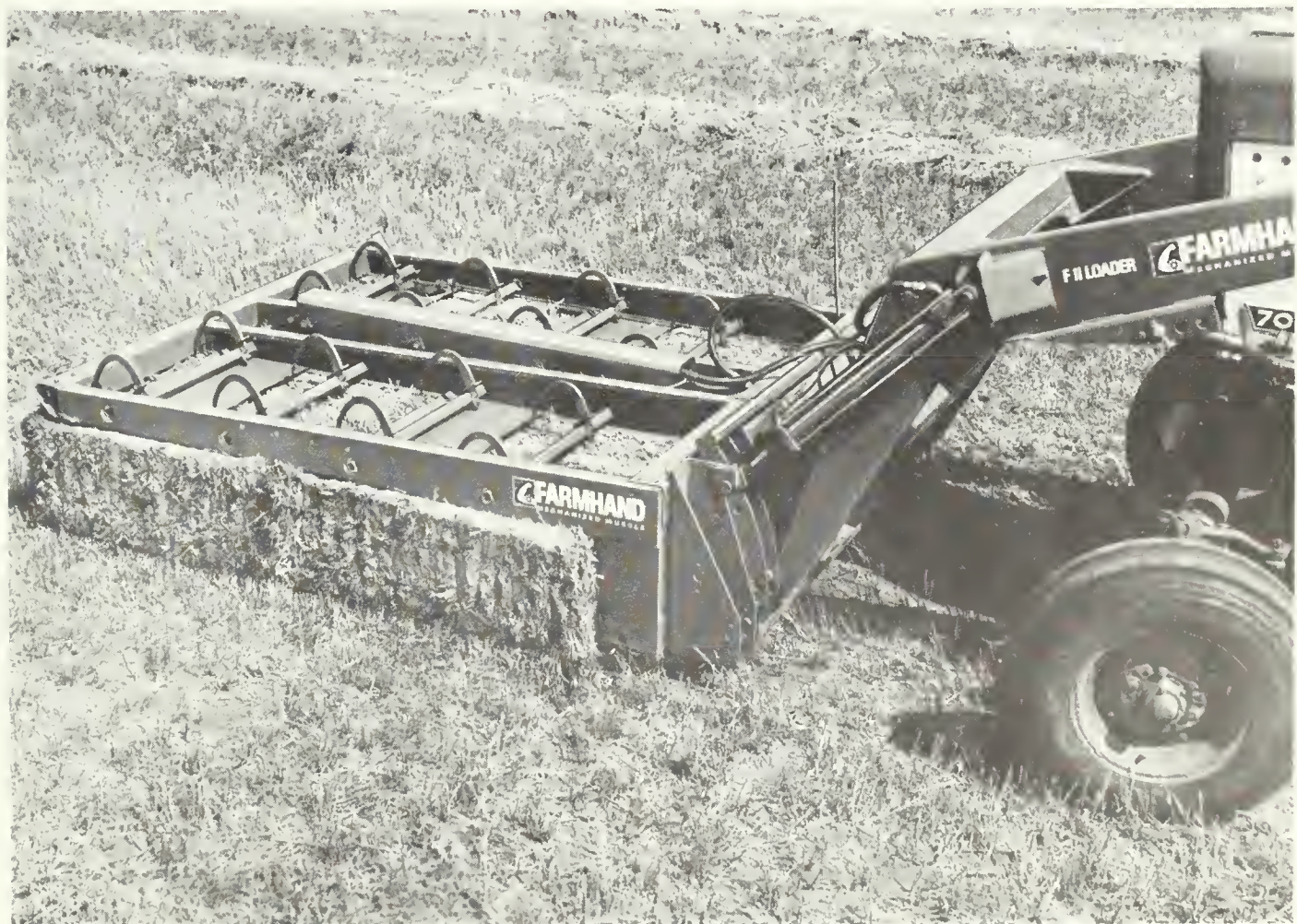

Figure 2.4.21 Hydraulically operated bale fork for stacking or unstacking 8 bales per operation. Courtesy: Farmhand Inc., Hopkins, Minn.



Figure 2.4.22 Rear-mounted loader with lift forks and push bar for removing round bales or other loads from forks. Courtesy: Sperry New Holland, New Holland, Pa.

2.4.5.1 Pallet Bin Unloaders

Hand labor is neither economical nor in some cases feasible for unloading pallet bins. Proper mechanical equipment is required to tip and hold loaded pallet boxes weighing 450 kg or more. The fruit industry has developed unloading devices which limit damage to the product. Four basic designs are used:

- end-gate dumping;
- partial inversion;
- complete inversion; and
- water submergence of bins.

1. *End-gate dumping:* To unload, pallet bins are tilted about 20 to 30°. A gate, about 300 mm high across the width of the bin, is opened to let the fruit roll out onto a sorting belt. Where a large number of bins are involved it may prove less costly to invest in a more expensive loader which can destack two to four standard bins placed on an infeed conveyor. A destacked bin is placed on a bin dumper that empties the produce onto a take-away conveyor or water flume. Bruise and stem puncture studies by McMechan (11) showed that relatively fresh McIntosh apples received more stem punctures from the partial inversion method than from the end-gate dumping method. With older fruit, the number of stem punctures increased four-fold with the partial inversion method.

2. *Partial inversion dumpers:* A fork lift is used to place a pallet bin on either a carriage on rails or on two parallel endless chains. The bin is pulled or pushed by hand or mechanical means onto a dumper consisting of a platform and padded lid. The dumper platform rotates the bin through 110° while the padded lid covers the bin to prevent fruit from rolling out. Once in position a hinged

section of the lid can be partially swung open to allow the fruit to roll out. Flow can be controlled by applying pressure on the release gate. The speed of emptying is limited only by the time required to position the bin and the capacity of the sorting belt. A recent development, shown in Figure 2.4.23, is a fork lift equipped with hydraulically operated bin dumper which rotates the bin up to 140° for emptying produce onto a sorting belt.

3. *Complete inversion:* This method employs two short sections of wide conveyor belts mounted on a framework that can be rotated through 180°. A full bin is sandwiched between the two belts, which serve as a platform and lid. After the bin is inverted it is moved from between the two belts onto an inclined conveyor. At the same time the fruit drops onto a separate conveyor to the grading line (11). This bin unloader was found to contribute about the same damage to the fruit as the end-gate dumper.

4. *Water submergence of bins:* This unloading device developed by Michigan State University pulls a pallet bin with produce under water. Apples, having a density less than water, are floated off. A circulating flow of water carries the apples away from the dumping mechanism to the end of the tank. At the end of the tank the produce is lifted out of the water by a roller conveyor.

The pallet bin is pulled below the water level by pneumatic or hydraulic cylinders attached to a frame which holds the bin and allows the apples to float out of the bin as shown in Figure 2.4.24.

The length of tank should be based on the time required to bring a bin into the next unloading position, and the speed of the grading line. The layer of fruit in the tank should supply enough apples to keep the grading line filled until



Figure 2.4.23 Hydraulic bin dumper rotates bin up to 140°. Courtesy: Edwards Equipment Co., Yakima, Wa.

the next bin starts to unload. Bruise studies have been favorable for this unloader; most damage occurs on the roller conveyor and the drier.

2.4.5.2 Vertical Silo Unloaders

Some advantages of silo unloaders are:

- The augers tend to cut and fluff the silage, which is preferred by the cattle.
- Mechanical unloaders make a more even cut and silage remaining is firm and will not spoil.
- Frozen silage is blended with unfrozen material, increasing edibility.

Three basic types of silo unloaders are available:

1. *Auger-blower unloader:* Most silo unloaders are of this type. The unloader consists essentially of one or two electrically operated augers equipped with knife sections that cut the packed silage loose and convey it to a blower. The blower impeller throws the silage through a curved chute to the silo access door and down the chute.

This type of unloader is usually suspended by cable, and can be pulled up into the dome of the silo during filling.

An added feature is the possibility of making a transfer track on top of two or more silos, provided all silos are the same height.

Another type, the chain and blower, rides on top of the silage. It can be cable-suspended, or it can be dismantled when the silo is empty for transfer to another silo.

Most silo unloaders have electric motors from 2.2 to 14 kW. They handle silos 3.6 to 12 m (12 to 40 ft) in diameter, except that most manufacturers use an additional auger for silos over 6.7 m diameter. In the latter case the silage is blown into an auger which conveys the material to the silo shaft.

Selecting an unloader should be based on both present and future needs.

- (a) Range of diameter: It is worthwhile to consider a loader that can be adapted to silos which may be built later. Also note whether the unloader will work in silos which are not perfectly circular.



Figure 2.4.24 Submersion dumper used in Okanagan packing plants.

- (b) **Weight of unloader:** a heavy unloader will most likely have a higher digging performance but will also require more power and be higher in price.
- (c) **Motors:** Unloaders with only one motor often have a high starting load. This may be overcome by lifting the unloader and lowering it into the silage once the mechanism is in motion. Separate motors for blowers and auger with sequence starting will permit the use of less expensive wiring.
- (d) **Time rating of motors:** The conditions in silos require a closed motor to eliminate dust. Since a sealed motor for continuous use is expensive, limited-use motors which are sealed can be run for 30 to 45 min continuously if allowed to cool before being used again. This is the way most silo unloaders are used.
- (e) **Driving wheels:** Both rubber and cleated steel wheels are used for driving the unloaders. There is little preference for one over the other, except that in very cold regions steel tends to freeze to the silage.

2. **Auger unloader:** Some silos, in which a vertical shaft is made in the silage at the time of loading, require only a horizontal auger or augers to bring the material to the center of the silo. The vertical shaft is made by suspending a metal cylinder in the silo as it is being filled, leaving a hole up the center of the silage. A 2.2 kW motor can be used with this system compared with a 5.6 kW motor using the conventional auger-blower system.

Since blowers or extra augers are not needed for large silos the cost decreases. The motors and the equipment can be much lighter and is therefore cheaper. Two disadvantages are that the core is exposed to air, therefore requiring oxygen-limiting silo construction and the shaft may collapse.

3. **Bottom unloader:** The bottom unloader works on the principle that once a thin layer of silage has been cut away the whole load will move down gradually. This unloader requires a smooth wall to allow the core to slip down. Over-wet silage may freeze to the silo wall as well.

The unloader consists basically of two parts, the gatherer and the transporter. The gatherer can be a continuous chain or an auger which is rotated around the center of the silo under the silage. This gives the endless chain or auger new material and brings the loosened silage to the center of the silo. The silage then drops through a hole in the floor into another conveyor below where it is conveyed outside. See also section 6.2.

2.4.5.3 Horizontal Silo Unloaders

The unloading of horizontal or trench silos is not completely satisfactory. One difficulty is that a large surface area of silage is exposed and can subsequently spoil, especially when standard tractor-powered forks or scoops are used for unloading. The scoops and forks leave the face of the silage bed ragged and loose, which can result in a high spoilage rate. Rapid consumption and frequent unloading will minimize the loss.

For large quantities of silage the horizontal silo is one of the most economical storages. For smaller units (less than 100 t), however, costs increase because of:

- higher equipment and labor costs for filling;
- higher fermentation losses;
- higher equipment and labor costs for unloading;
- higher feed-out losses.

Specially designed unloaders are available for mounting on a tractor or truck. These consist of a hydraulically operated cutting head, a hopper with auger feed, and a blower or chain conveyor to elevate the cut material into a feed bunk, wagon or truck. The cutting head has knives attached to cross bars and the whole unit can cut from over 4 m to ground level.

One special-purpose unloader has a vertical cutter that is automatically winched across the face of the silage. Concentrate held in a bin on the machine is metered and mixed in as the silage is cut. As the cattle push against the manger to feed, the unit is kept in contact with the silage face (see Figure 2.4.25). As a result, the exposed silage



Figure 2.4.25 Silage cutter and concentrate hopper. Unit is advanced by cattle pressing against the mangers. Courtesy: Future Feed Lots Ltd., Brampton, Ont.

face is much smoother than that left by front-end loaders and spoilage is substantially reduced. Kemp and Melanson did a cost analysis of front-end silage unloaders and specialized silo unloaders (10). Their results are summarized in Figures 2.4.26 to 2.4.29 inclusive.

2.4.5.4 Wagon Unloaders

If mechanical devices are not used, considerable manual labor is required to handle silage. Some devices have been developed to unload wagons:

1. **Canvas apron:** A canvas sheet is laid on the bottom of the wagon or truck before being loaded. When the load is to be removed the apron is drawn onto a roller fastened to the rear edge of the wagon deck. The canvas tends to stretch and hence reduces the discharge rate slightly. The roller is powered by either a hand ratchet or an auxiliary motor.
2. **Slatted floor chains:** Slatted floor chains are used as unloading devices in manure spreaders, silage wagons, etc. (Section 2.1). The endless chains run over the deck and return underneath. Driving sprockets are at one end of the wagon as shown in Figure 2.4.30 and are powered by auxiliary motors or PTO. These units may hold up to 6.5 t of silage and can be used to supply forage to a vertical silo loader as seen in Figure 2.4.31. Handling rates of at least 34 m³/h should be maintained to harvest forage at its best quality.

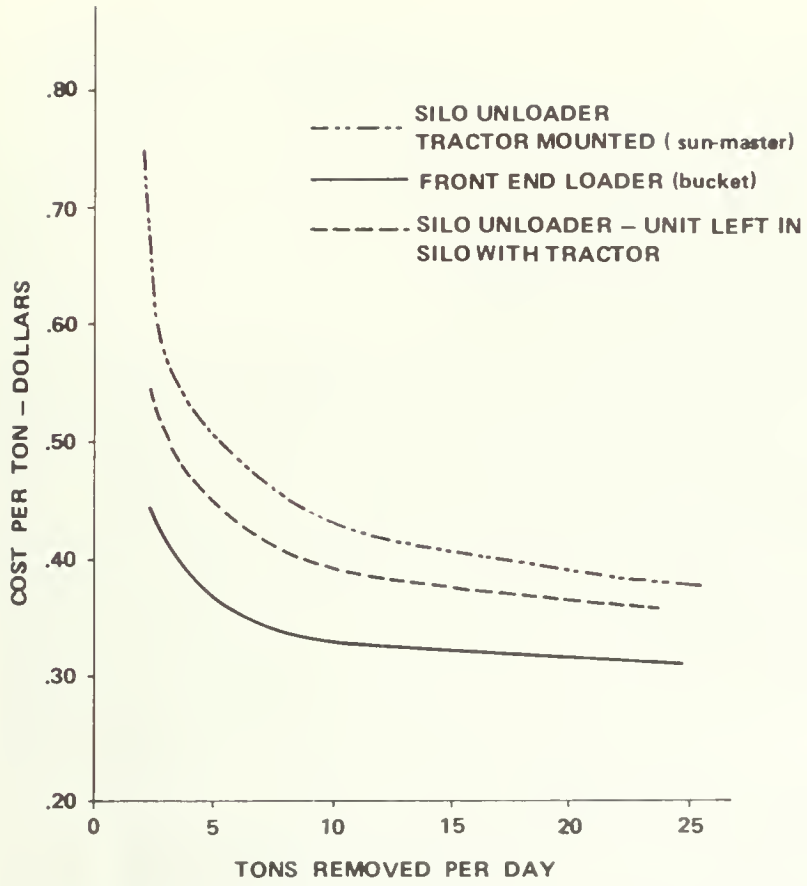

Figure 2.4.26 Effect of tons removed per day from horizontal silos on cost per ton.

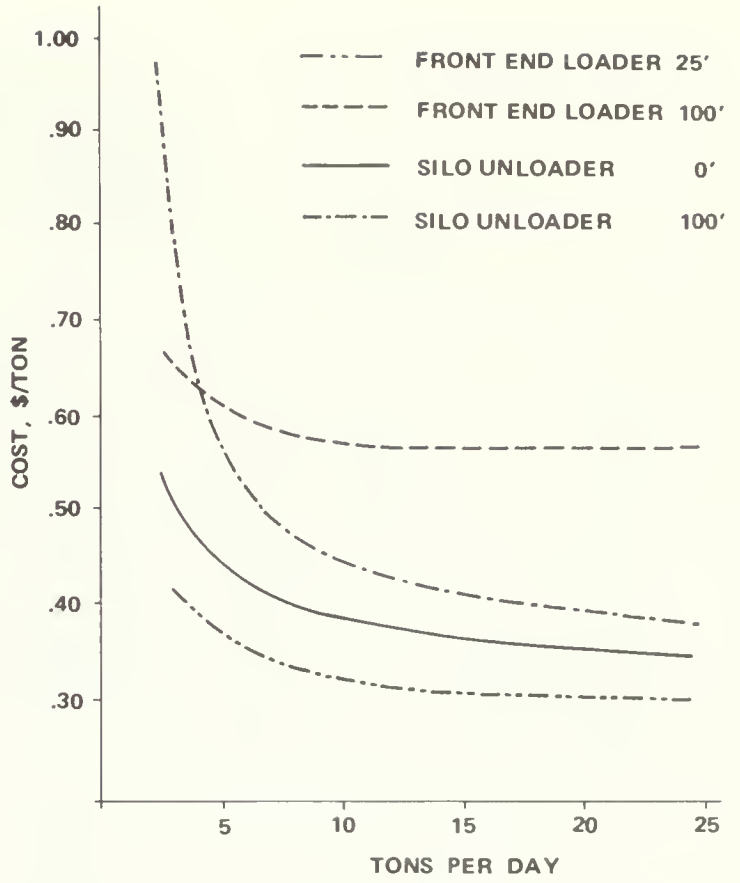

Figure 2.4.28 Effect of travel distance on cost per ton.

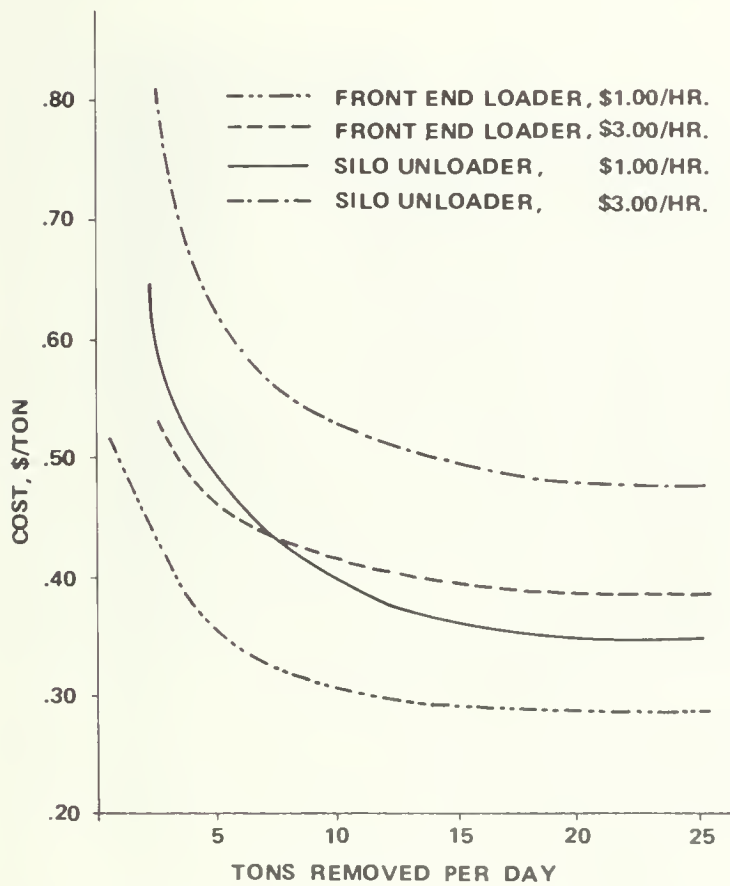

Figure 2.4.27 Effect of labor costs on cost per ton.

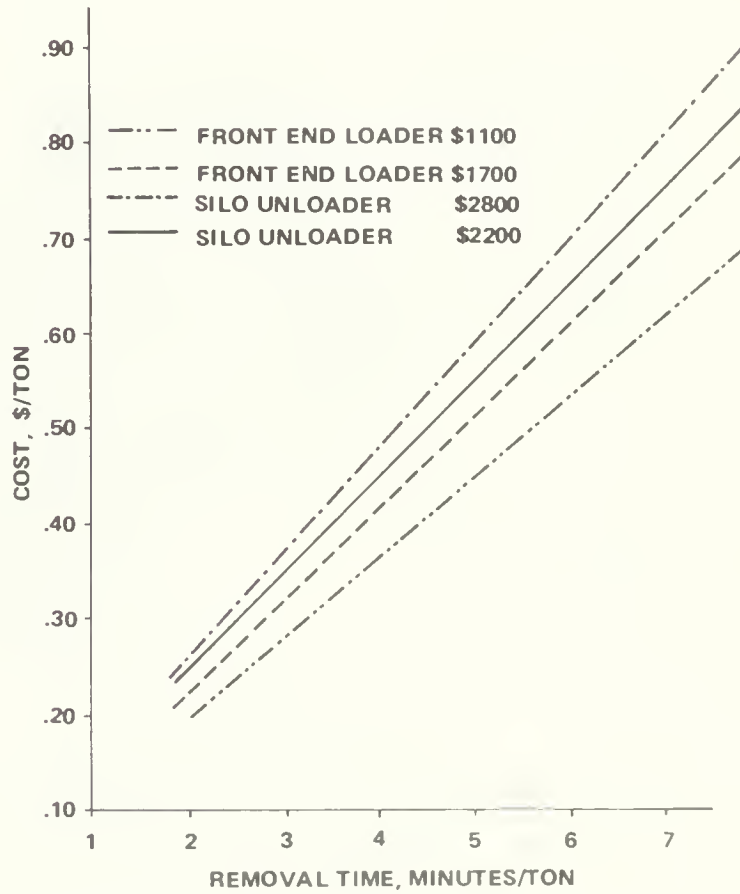

Figure 2.4.29 Effect of removal time and equipment costs on cost per ton from horizontal silos.



Figure 2.4.30 PTO powered chain and slat self unloading wagon. Courtesy: Sperry New Holland, New Holland, Pa.



Figure 2.4.31 Self unloading wagon supplies chopped forage to forage blower. Courtesy: Gehl Co., West Bend, Wisconsin.

3. *Auger box wagon:* This is a recent development by at least one farm equipment manufacturer. A longitudinal auger runs the entire length of a wagon box. When the box is filled the auger is under a sloping shelf to one side. To unload, the tractor PTO is engaged and the drive assembly moves the auger back and forth across the bottom of the box. This movement carries material to the front of the wagon and into a cross conveyor.

4. *Dumping wagons:* One of the simplest ways to empty a wagon or truck is to tip the box so that the load slides out. The box should be hinged at the back, and equipped with a hydraulic dump.

The capacity of dump wagons is limited by the design of the box or by the hydraulic system.

An ordinary truck or wagon body can be used as a dumping unit by blocking the rear wheels and lifting the complete front. The hoist can be made by passing a fixed length of cable over a pulley mounted on a hydraulic piston. One end of the cable is anchored to the frame of the hoist while the other end is attached to the front of the truck or wagon. This system is sometimes used for dumping grain trucks at a receiving station.

2.4.6 TRANSPORT

Transport by unitized conveyors is accomplished in a number of ways. Recommendations for handling or moving various agricultural materials should be based on cost and time studies of each type of equipment.

2.4.6.1 Stationary Conveyor Units

Stationary transport equipment is used to move packaged and non-free-flowing solids through distances less than 30 m. The items discussed may have limited application, but nevertheless can be most useful for solving farm materials handling problems.

Roller conveyors can only be used to handle unit loads, such as boxes, bags and bales. They can be made to go around curves at 90° corners, or made portable for use in different locations. Basically, there are two distinct types:

1. *Rollers:* Rollers are from 38 to 51 mm (1½ to 2 in.) in diameter. They are made of 12 to 16 gauge plain or galvanized welded steel tubing carried in steel frames of 10 to 12 gauge material. Complete conveyor sections are available in steel or aluminum, in straight sections 1.5 m (5 ft) and 3 m (10 ft) long and in widths of 305 mm to 1370 mm (12 to 54 in.), in increments of 76 mm (3 in.). Curved

sections are available in 45° and 90° turns in single and double lane types. The conveyor slope may vary from 1.3:100 to 7.5:100 depending on the nature of the containers to be conveyed; smooth steel drums require less slope than cardboard cartons or baled hay. At least three rollers should support the item conveyed at all times. With flat-bottomed objects, 75 or 100 mm overhang is considered safe for straight runs. When the system includes curves, the carrying surface of the rollers must be at least 50 mm wider than the widest item the conveyor will handle. Where long runs are involved, power booster units should be used to re-elevate material for continued travel by gravity. Live-roller conveyors driven by a flat belt held tightly against the underside of the conveyor can be used to convey material at zero slope. Distributed load capacities are given in Tables 2.4.2 and 2.4.3. Load capacities should be calculated to include the weight of the conveyor itself.

2. *Wheels:* The wheel gravity conveyor, like the roller gravity conveyor, consists essentially of interchangeable wheel and axle assemblies. Cartons, multi-wall sacks and other containers that will indent slightly under their own weight have less tendency to slide sideways on a wheels than on a roller conveyor, allowing longer runs at higher speeds. Wheels resolve independently on curves, giving perfect differential action and maintaining accurate alignment of containers. Wheel conveyors require up to 50% less slope than roller conveyors of equal carrying capacity. Wheels are generally 51 mm (2 in.) in diameter with 16 mm (5/8 in.) face and may be either aluminum or galvanized steel.

Specifications for wheel conveyors are given in Tables 2.4.4 to 6 inclusive.

TABLE 2.4.2 Maximum Capacities of Rollers, Based on Linear Speed of 25 ft/min

Roller Construction	kg	lb
48 mm (1.9 in.) diam 12 ga steel	113	250
48 mm (1.9 in.) diam 16 ga steel	68	150
48 mm (1.9 in.) diam aluminum	36.3	80
44 mm (1.75 in.) diam 16 ga steel	22.7	50
44 mm (1.75 in.) diam aluminum	18.1	40

NOTE: The limiting factor appears to be the bearing support within the roller and not the length of the roller. If the roller bearings are replaced with a ring bearing of Delrin, the capacity is reduced to 13.6 kg (30 lb).

TABLE 2.4.3 Maximum Capacities of Frames

Frame Construction	1.5 m (5 ft) Section		3 m (10 ft) Section		3 m (10 ft) Section Supported 1.5m OC	
	kg	lb	kg	lb	kg	lb
10 ga steel 89 mm (3.5 in.) channel	1225	2700	590	1300	2450	5400
10 ga steel 100 mm (4.0 in.) channel (rollers set "low")	1485	3275	714	1575	2971	6550
3 mm (i in.) aluminum, 89 mm (3.5 in.) channel	671	1480	331	730	1343	2960
12 ga steel 63 mm (2.5 in.) channel	680	1500	363	800	1361	3000
12 ga steel, 100 mm (4.0 in.) channel (rollers set "low")	454	1000	567	1250	907	2000
3 mm (i in.) aluminum, 63 mm (2.5 in.) channel	454	1000	227	500	907	2000

TABLE 2.4.4 Specifications for Straight Sections — Aluminum Frames and Wheels

Frame Width		No. of Wheels		63 mm (2.5 in.) Frame, Wheels Set "High"								90 mm (3.5 in.) Frame, Wheels Set "High"							
				1.5 m (5 ft)				3 m (10 ft)				1.5 (5 ft)				3 m (10 ft)			
				Cap.		Wt.		Cap.		Wt.		Cap.		Wt.		Cap.		Wt.	
mm	in.	Per m	Per ft	kg	lb	kg	lb	kg	lb	kg	lb	kg	lb	kg	lb	kg	lb	kg	lb
305	12	10	6	163	360	8	18	238	525	15	33	163	360	9	19	327	720	16	35
		26	8	218	480	9	19	238	525	16	36	218	480	9	20	333	735	17	38
		33	10	272	600	9	20	238	525	18	39	272	600	10	21	333	735	19	41
		39	12	327	720	10	21	238	525	19	42	327	720	10	22	333	735	20	44
		52	16	435	960	10	23	238	525	22	48	435	960	11	24	333	735	23	50
457	18	39	12	327	720	10	23	238	525	22	48	327	720	11	24	333	735	23	50
		46	14	381	840	11	25	238	525	23	51	381	840	12	26	333	735	25	53
		52	16	435	960	12	27	238	525	24	54	435	960	13	28	333	735	25	56
		59	18	476	1050	13	29	238	525	26	57	667	1470	14	30	333	735	27	59
610	24	52	16	435	960	14	31	238	525	27	59	435	960	15	32	333	735	28	61
		59	18	476	1050	15	32	238	525	28	61	667	1470	15	33	333	735	29	63
		66	20	476	1050	15	33	238	525	29	63	667	1470	15	34	333	735	39	65
		79	24	476	1050	16	35	238	525	30	67	667	1470	16	36	333	735	31	69
		92	28	476	1050	17	37	238	525	32	71	667	1470	17	38	333	735	33	73

TABLE 2.4.5 Specifications for Straight Sections — Aluminum Frames, Steel Wheels

Frame Width		No. of Wheels		63 mm (2.5 in.) Frame, Wheels Set "High"								90 mm (3.5 in.) Frame, Wheels Set "High"							
				1.5 m (5 ft)				3 m (10 ft)				1.5 (5 ft)				3 m (10 ft)			
				Cap.		Wt.		Cap.		Wt.		Cap.		Wt.		Cap.		Wt.	
mm	in.	Per m	Per ft	kg	lb	kg	lb	kg	lb	kg	lb	kg	lb	kg	lb	kg	lb	kg	lb
305	12	10	6	340	750	10	21	238	525	18	39	340	750	10	22	333	735	19	41
		26	8	454	1000	10	23	238	525	20	44	454	1000	11	24	333	735	21	46
		33	10	476	1050	11	25	238	525	22	49	567	1250	12	26	333	735	23	51
		39	12	476	1050	12	27	238	525	24	53	667	1470	13	28	333	735	25	55
		52	16	476	1050	14	30	238	525	29	63	667	1470	14	31	333	735	29	65
457	18	39	12	476	1050	13	28	238	525	27	59	667	1470	13	29	333	735	28	61
		46	14	476	1050	14	31	238	525	29	64	667	1470	13	29	333	735	30	66
		52	16	476	1050	15	34	238	525	31	68	667	1470	16	35	333	735	32	70
		59	18	476	1050	17	37	238	525	33	73	667	1470	17	38	333	735	34	75
610	24	52	16	476	1050	18	39	238	525	34	75	667	1470	18	40	333	735	35	77
		59	18	476	1050	19	41	238	525	36	79	667	1470	19	42	333	735	37	81
		66	20	476	1050	20	43	238	525	38	83	667	1470	20	44	333	735	39	85
		79	24	476	1050	21	47	238	525	42	92	667	1470	22	48	333	735	43	94
		92	28	476	1050	23	51	238	525	45	100	667	1470	24	52	333	735	46	102

TABLE 2.4.6 Specifications for Straight Sections — Steel Frames and Wheels

Frame Width		No. of Wheels		63 mm (2.5 in.) Frame, Wheels Set "High"								100 mm (4 in.) Frame, Wheels Set "Low"							
				1.5 m (5 ft)				3 m (10 ft)				1.5 (5 ft)				3 m (10 ft)			
				Cap.		Wt.		Cap.		Wt.		Cap.		Wt.		Cap.		Wt.	
mm	in.	Per m	Per ft	kg	lb	kg	lb	kg	lb	kg	lb	kg	lb	kg	lb	kg	lb	kg	lb
305	12	10	6	340	750	15	33	363	800	30	67	340	750	18	40	567	1250	37	81
		26	8	454	1000	16	35	363	800	32	71	454	1000	19	42	567	1250	39	85
		33	10	567	1250	17	37	363	800	34	75	567	1250	20	44	567	1250	40	89
		39	12	680	1500	18	40	363	800	35	78	680	1500	21	46	567	1250	42	92
		52	16	726	1600	20	45	363	800	39	85	907	2000	24	52	567	1250	45	99
457	18	33	10	567	1250	18	40	363	800	37	82	454	1000	21	47	567	1250	44	96
		39	12	680	1500	19	42	363	800	39	86	680	1500	22	49	567	1250	45	100
		46	14	726	1600	20	45	363	800	41	90	794	1750	24	52	567	1250	47	104
		52	16	726	1600	21	47	363	800	43	94	907	2000	24	54	567	1250	49	108
		59	18	726	1600	22	49	363	800	44	98	1134	2500	25	56	567	1250	51	112
		66	20	726	1600	24	53	363	800	47	104	1134	2500	27	59	567	1250	54	118
610	24	52	16	726	1600	27	59	363	800	51	113	1134	2500	39	64	567	1250	58	128
		59	18	726	1600	28	61	363	800	53	117	1134	2500	31	68	567	1250	52	136
		66	20	726	1600	29	63	363	800	55	121	1134	2500	32	70	567	1250	64	140
		79	24	726	1600	30	67	363	800	59	129	1134	2500	34	74	567	1250	67	148
		92	28	726	1600	32	71	363	800	62	137	1134	2500	35	78	567	1250	71	156

2.4.6.2 Mobile Conveyor Units

This section includes self-propelled units and units pulled by tractors and other vehicles.

1. *Sled*: The sled is one of the simplest and oldest forms of transport. The stoneboat or sled was used by the earlier pioneers, and is still of use in areas where conventional wheeled units will not travel. The sled is made of two lengths of log or sawn timber forming runners whose ends have been bevelled to facilitate sliding over the ground. The runners are laid under a deck of planks which support the load. The sled is pulled by tractor or horse and can be used only on private roads since damage is sometimes inflicted on improved roads. Sleds are suitable for hauling empty bins, sacked potatoes and for other field work. They are unexcelled for hauling over rough bush terrain or for operation over snow.

2. *Wagons*: Sizes of wagons used on farms are too numerous to be listed here. The ASAE has developed a set of standards for sizes and clearances of wagons. The latter is especially important when trailing behind forage blowers or other harvesting equipment. The standards were developed to assist designers of farm equipment to standardize their machines and allow for interchangeability (1). Figure 2.4.32 shows the essential dimensions that are controlled, so that designers of wagons and grain-harvesting machines may have the greatest possible latitude in their design.

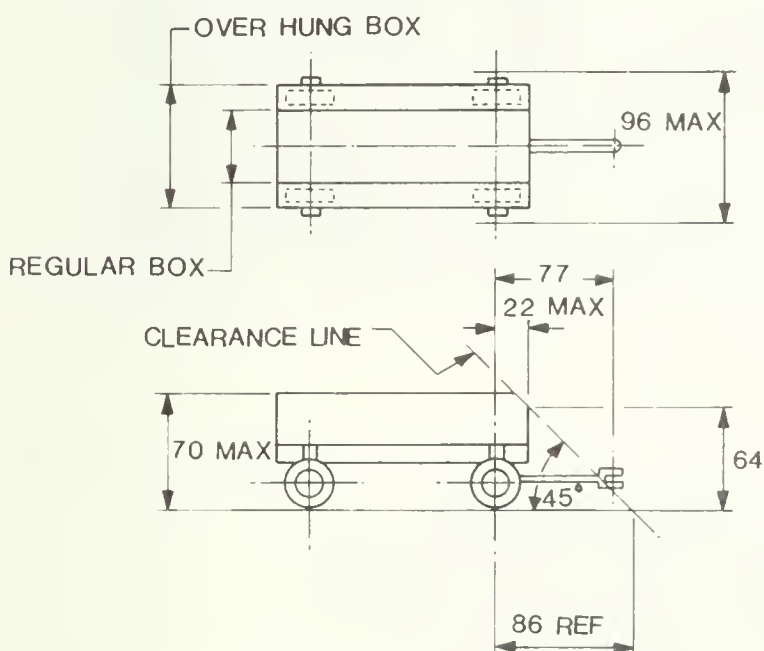

Figure 2.4.32 ASAE recommended hitch and box Dimensions for farm grain wagons: ASAE Yearbook 1975. Dimensions are inches.

(a) Volumetric capacity: The ASAE approved a set of standards for the calculation of volumetric capacity of forage wagons, wagon boxes, and forage-handling adaptations of manure spreaders (ASAE approved 1961, reconfirmed December 1978) (1). To conform to this standard, wagons must be rated struck level, using the inside dimensions of the box. In the case of forage wagons with mixing or agitating mechanisms at the front or rear of the box, the length shall be measured to the center of the beater shaft or to any restricting surface should the surface fall inside the center line of the shaft. If the beaters are not in place in a common vertical plane, the dimensions shall be calculated in accordance with a rectilinear system with steps to be made halfway between beater diameters.

(b) Load capacity: The volumetric capacity of a wagon cannot be the only criterion for maximum loads. The capacity load should be determined by either the volume or the maximum allowable load based on construction strength, wheels or tires. Whichever allowable load is least governs the load capacity for the particular material.

3. *Manure spreaders*: The manure spreader is a special-purpose farm transport unit with a mechanical unloading arrangement. A chain and slat conveyor moves the manure to the end of the trailer where beaters and spreaders distribute the load over a 2 to 3 m strip of land. Capacity of manure spreaders is by volumetric measurements using standardized calculations (ASAE approved 1958, revised 1971) (1). Manure handling is discussed in more detail in Section 3.5.

4. *Trucks*: Truck characteristics are so varied that no discussion could cover the subject. Consideration should be given to larger trucks with a load deck adaptable to other handling chores. A truck deck with dismountable sides can be used for a great variety of farm jobs. A dump box is another recommended feature if grain, dirt, gravel, fertilizer or manure is to be handled and unloaded as bulk material.

2.4.6.3 Hay Handling Units

Forages are the most important crops from several points of view. More land is devoted to them than to all other crops combined, taking up approximately five times the area of all grain crops. The dollar value of forages, expressed in terms of their importance to human food of animal origin, exceeds the value of any other crop. The U.S. Department of Agriculture reported in 1974 that 240 million tonnes of feed units for livestock were supplied from forages (1 feed unit is the nutritional equivalent of 0.454 kg of corn grain) (8).

There are three basic hay handling systems that are in current use. Some of their essential characteristics are discussed in the following. For a more detailed discussion on specific units and operating costs see reports by Padbury (12) and Friesen (4).

These basic systems are loose hay, rectangular bales and large round bales.

Large cylindrical twine-wrapped hay bales are gaining rapid acceptance. This is primarily due to two factors: the virtual elimination of hand labor compared to other hay handling systems and the weather resistant characteristics of large bales allows unprotected outside storage. After the bales are made they can be moved, stored and fed one bale at a time, using various tractor-mounted or drawn equipment (14).

1. *Factors influencing haying system selection*: In addition to economic factors covered under part (5) following, there are other important factors which influence the final choice of system and equipment:

- Labor available.
- Capital available.
- Volume of hay to be harvested in a given period.
- The availability of existing storage facilities and existing equipment that can be used for harvesting, hauling, feeding, processing or handling.
- Time available for harvesting hay.
- Type of forage to be harvested.
- Distance to transport hay.
- Flexibility of system to other crops such as straw or silage.

- The potential to defer some stages of the harvesting and hauling off peak workload periods or during poor weather.
- The influence on feed quality.
- The type of field conditions such as open fields, sloughs, ditches and rough terrain.
- Problems associated with winter feeding such as snow build-up, mud, starting tractors and feed wastage.
- The potential for sharing ownership of expensive equipment or of obtaining or doing custom work.

2. *Loose hay handling:* There is a new interest in loose hay handling since new developments are taking place in mechanical equipment. The variation is from simple hay sweeps and stacking to sophisticated mechanical stackers. The principal advantages are low labor inputs, weather-resistant stacks, and high capacity. The principal disadvantages are high capital cost, high degree of operating skill, possible need to modify feeding facilities, and feeding losses may be greater.

Figures 2.4.33 and 2.4.34 show two stack formers currently available.



Figure 2.4.33 Hay stacker and mover. Courtesy: McKee Bros. Ltd., Elmira, Ont.



Figure 2.4.34 Hay stacker former. Courtesy: McKee Bros. Ltd., Elmira, Ont.

- (a) In the first, hay is blown into the stack former and is compacted by its own weight and by vibrations produced by travelling across the field. When filled, the rear doors are opened and chain conveyors in the floor of the former moves the load to the rear. The box and floor are tilted to ease the stack gently to the ground. By removing the box, the unit can be used to reload the stack for transport to a storage area or feeding area. Loads vary from 4.5 to 5.4 t of grass-legume hay and 3.6 to 4.5 t of wild hay. Loading times vary from ½ to ¾ hours.
- (b) The unit shown in Figure 2.4.34 is filled in much the same way, but when the box is full the outfit is stopped and the roof lowered by hydraulic cylinders to pack the stack. The unit is then refilled and packed through four to 12 cycles. As in the previous unit, chain conveyors in the floor move the stack out of the unit either directly onto the field or else it is taken to a storage area if the hauling distance is short. Stack weights are between 1.8 to 2.3 t. The average harvesting rate is about 7.3 t/h or about 18 minutes to build and unload a stack. Losses during loading and transport may be significant as well as weathering losses if the top is not perfectly shaped. Mold and rotted hay in the top layer is not uncommon.
- (c) Another unit consists of pick-up and vertical conveyor which delivers the hay into a rotating cylindrical cage. A drum-type roller in the cage packs the hay. Cage diameters are 3.3, 4.9 and 5.5 m. Stack heights are up to 5 m. Again, when the cage is full, rear doors are opened and conveyor chains in the floor move the stack out of the cage. The floor and cage are tilted during this operation to lower the stack onto the ground. This unit can also reload the stack for later transport to storage or feeding area. The average time to build and unload a 4.5 to 5.4 t stack is ½ to ¾ hours. Figure 2.4.35 is an example of a cylindrical cage baler.



Figure 2.4.35 Hay stacker. Courtesy: G.E. Padbury.

3. *Rectangular bales:* This hay handling method is popular since bales can be handled manually or with complete mechanization. Bales are particularly adaptable to long-distance transport and hence are the chief form for marketed hay. Manually handled bales are around 22 kg and mechanically handled bales may be 27 kg or over.

- (a) Bale stokers are units which trail behind the baler and arrange the bales into units of 6, 10 or 15 bales

placed on edge to form a pyramid. A front-end loader on a tractor raises the bales onto a wagon. The bales are usually arranged manually on the wagon.

- (b) Bale accumulator systems such as shown in Figure 2.4.21 are closer to one-man operation. An accumulator on the baler leaves packs of eight bales in the field. A tractor front-end loader arrangement picks up the pack and loads a wagon or truck; it can also be used to unload and build a storage stack. Friesen (4) reports that one man using this unit can load six to eight bales per minute onto a wagon. Unloading the wagon and building a stack can be done at the rate of eight to 10 bales per minute. These rates were based on reasonably smooth fields yielding about 125 bales/ha. Heavier bales improve the efficiency of operation and should be 23 to 36 kg.
- (c) A mechanical bale wagon system consists of a baler with a quarter-turn bale chute and a mechanical bale wagon that picks up the bales and stacks them on a wagon deck. The unit transports the bales to a storage area where the deck is tilted to unload the wagon into a stack seven to nine bales high. Friesen (4) reports that an experienced operator working on smooth fields with a yield of 125 to 150 bales/ha can achieve a loading rate of 5-10 bales per minute for a small machine and up to 15-30 bales per minute for a larger self-propelled bale wagon. Unloading time is about 5 minutes. Figure 2.4.36 shows a self-propelled unit



Figure 2.4.36 Automatic bale wagon can pick-up, load, transport and unload in stacks from 1.8 to 5.5 t (2 to 6 tons) per load. Courtesy: Sperry New Holland, New Holland, Pa.

picking up a bale from the field to form a stack on the wagon deck. Figure 2.4.37 shows a pull-type unit unloading at a nine-bale-high stack. Some pull-type models can unload one bale at a time onto a bale elevator for mow storage shown in Figure 2.4.38. Another possibility with some models of mechanical bale wagons is to use an attachment that retrieves stacked baled hay for moving to a new location or for feeding as shown in Figure 2.4.39. Considerable operator skill is required for efficient operation. A bulkhead of bales or poles is required to start a stack from a bale wagon. Stacks should be covered to reduce spoilage in heavy rainfall areas.

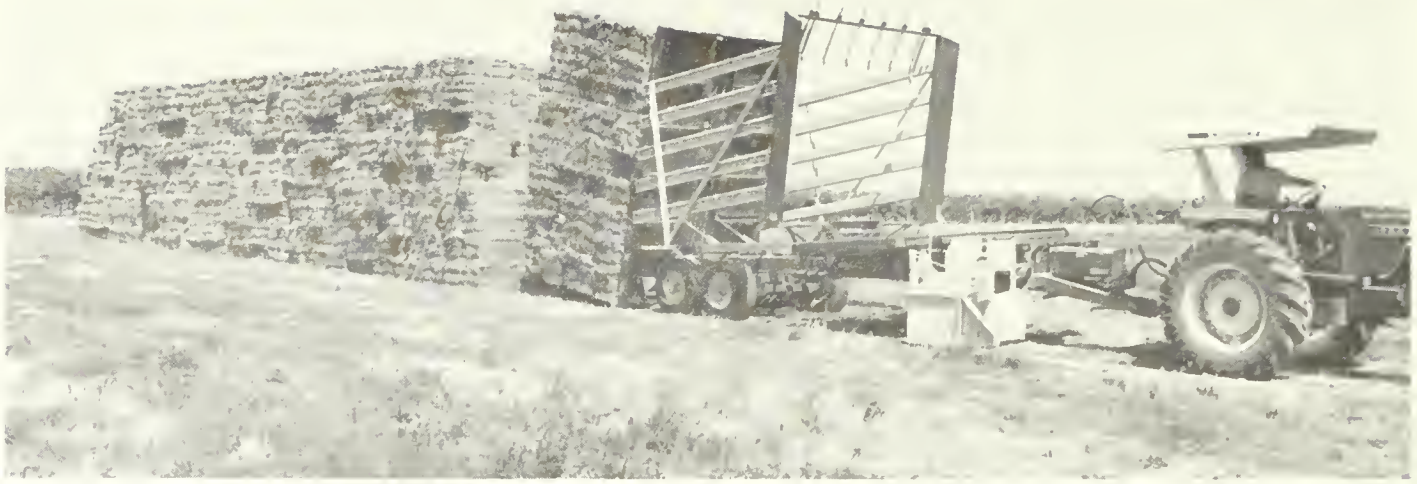

Figure 2.4.37 Pull-type bale wagon unloading at a 9 bale high stack. Courtesy: Sperry New Holland, New Holland, Pa.

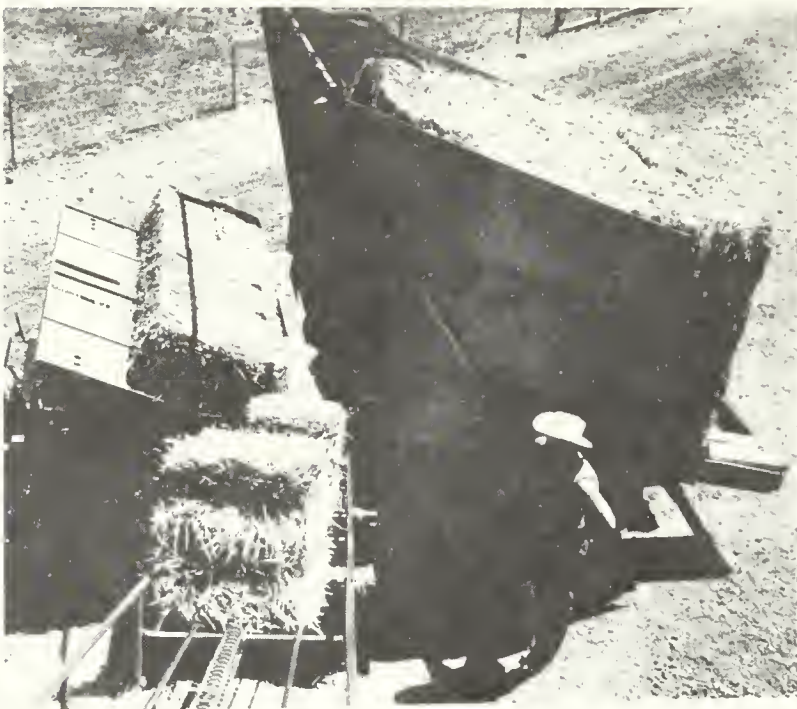

Figure 2.4.38 Pull-type bale wagon used to unload one bale at a time onto a bale elevator. Courtesy: Sperry New Holland, New Holland, Pa.



Figure 2.4.39 Self-propelled bale wagon equipped with a retriever to move entire baled hay stacks to feeding area or other stack location. Courtesy: Sperry New Holland, New Holland, Pa.

- (d) Bale elevators (like Figure 2.4.40) are made from square or round tubes to form the basic frame. These elevators may be inclined or, with a suitable cage, mounted vertically against a barn wall. A single chain #45 or #55 pintel type is usually used with flights attached at intervals of at least one bale length. The usual width of the elevators is 360 mm. to accommodate most bales. Electric motor drives are most frequently used but gasoline engines are also in use (13).

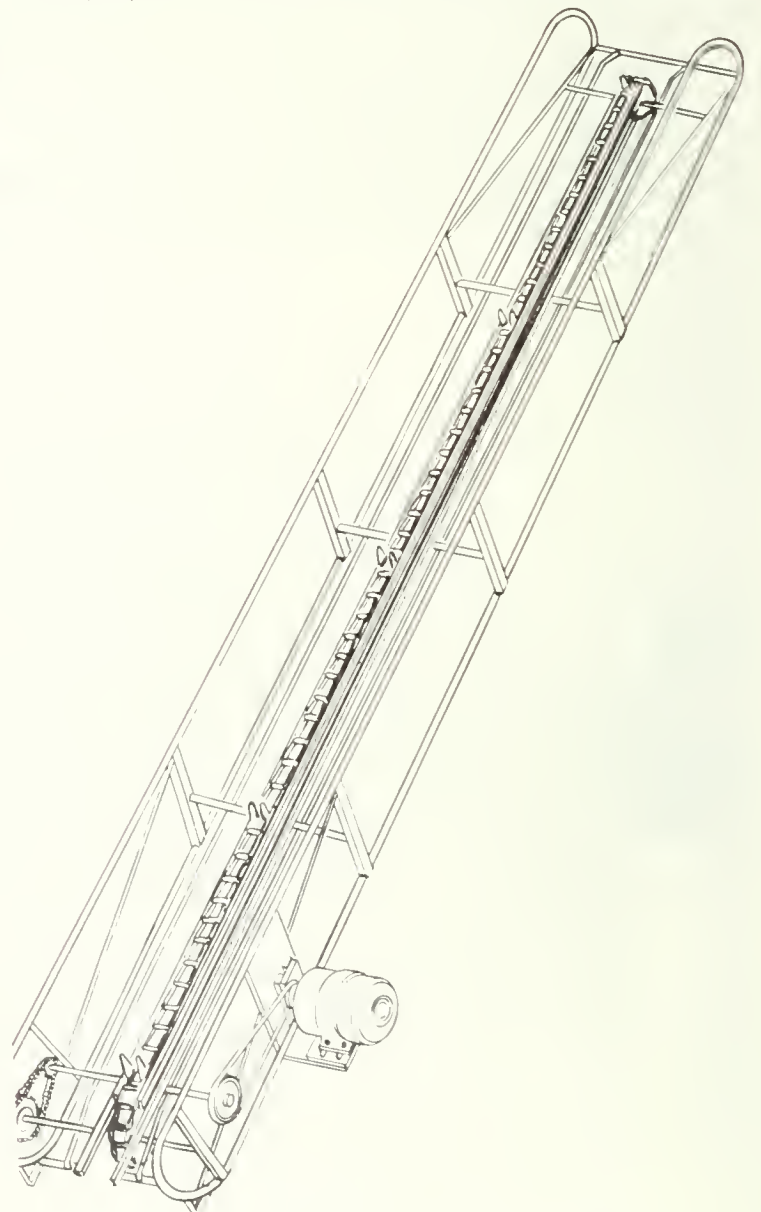

Figure 2.4.40 Portable bale elevator. Courtesy: Ministère de l'Agriculture du Québec.

4. *Round bales:* There are two basic types of round bales; one is formed by rolling the windrow of forage between belts until the desired size is reached and the other rolls the windrow along the ground, like rolling up a carpet. Twine may be wrapped around the bale to help hold it together.

(a) Figure 2.4.41 shows a typical round baler using endless belts. Twine is wrapped in a spiral around the bale before it is ejected onto the ground. Bale diameters are about 1.5 m and weights may be 0.5 to

0.6 t. Approximately 3¾ minutes are required to make and unload a bale. If bales are in contact with each other and left uncovered, mold and rotten hay develop at areas of contact.

(b) Chains with cross bars may also be used to roll hay along the ground until a round bale up to 2 m diameter is formed. Bales are left in the field for later pickup with fork lift or other units since this baler cannot transport the bales. Bale weights average about 0.4 to 0.5 t and require about 3 minutes to form and unload



Figure 2.4.41 Belt type round baler. Courtesy: Gehl Company, West Bend, WI.



Figure 2.4.42 Big bale fork attachment for front-end tractor loader will handle 1.5 to 2.1 m bales. Courtesy: Farmhand Inc., Hopkins, Minn.



Figure 2.4.43 Big bale mover with hydraulic operated lift forks to raise bale onto transport bed. Courtesy: Farmhand Inc., Hopkins, Minn.

(c) Pickup devices such as front-end loaders (Figure 2.4.42) and units such as the ones in Figures 2.4.42 to 2.4.45 can be used to pick up, transport and stack large round bales. The unit shown in Figure 2.4.43 has hydraulically operated fork lifts to transfer the bale from the field to the bed of the transporter. Hydraulically operated pintle chain moves the bale rearward on the bed. Depending on the size of the unit

three to five bales can be transported to a storage area at one time. Figure 2.4.45 shows a tractor rear-mounted single bale pickup. This unit is particularly useful for stacking and for feeding out operations.

5. *Economic comparisons:* A Saskatchewan Department of Agriculture study in 1977 (18) has indicated a wide range of forage harvesting costs. Large round bales

and high tonnages can be produced at the lowest cost. Conventional rectangular bales range from \$10.96/t for 900 t to \$54.37/t for 90 t. Loose hay costs range from \$7.71/t for 900 t to \$40.45/t for 90 t. Large round bales range in cost from \$4.94/t for 900 t to \$19.27/t for 90 t. For more detailed costing of machine components reference 18 should be studied.



Figure 2.4.44 Tilting-bed big bale transporter with twin transfer chain. Courtesy: Sperry New Holland, New Holland, Pa.



Figure 2.4.45 Tractor rear-mounted single bale pick-up attachment. Can be used for stacking and unrolling for cattle feeding. Courtesy: Gehl Company, West Bend, WI.

2.4.7 REFERENCES

1. American Society of Agricultural Engineers, "Approved Standards, Recommendations, Codes and Data", Agricultural Engineers Yearbook, ASAE, 1978.
2. Apple, J.M., Material Handling System Design, Ronald Press Co., New York, 1972.
3. Bainer, R., R.A. Kepner, E.L. Barger., Principles of Farm Machinery, John Wiley & Sons Inc., New York, 1955.
4. Friesen, O.H., Hay and Forage Handling Methods Used in Manitoba, Technical Services Branch, Manitoba Department of Agriculture, 1974.
5. Hagemann, G.E., Materials Handling Handbook. The Ronald Press Company, New York, 1958.
6. Heebink, T.B., Load Carrying Capacity of Deck Boards for General-Purpose Pallet, Publication 2153, Forest Products Laboratory, U.S.D.A., Madison, Wisconsin, August 1959.
7. Heebink, T.B., Survey of Wood Bin Pallets used for Harvesting and Storing Apples. U.S.D.A. Forest Products Laboratory, Madison, Wisconsin, Report #2115, 1958.
8. Hodgson, H.J., Forage Crops, Scientific American, Vol. 234, No. 2, February 1976.
9. Immer, J.R., Materials Handling, McGraw-Hill, Toronto 1959.
10. Kemp, J.G. and B.A. Melanson., Report on Horizontal Silo Unloading, A.E. Publication #2, Agric. Canada Research Sta., Fredericton, N.B., October 1974.
11. McMechan, A.D., and W.F. Morton, The Bulk Bin Method of Handling Fruit in British Columbia, Publication 12, Canadian Department of Agriculture, Summerland, B.C., July 1958.
12. Padbury, G.E., Forage Mechanization, Saskatchewan Department of Agriculture, 1974.
13. Perron, P., G. Jacob, R. Benjamin, and R. Gingras. Choix et Utilisation des Monte-Balles, Div. des Machinisme Agricole, Quebec Ministere de l'Agriculture.
14. Richey, C.B., P. Jacobson, and C.W. Hall., Agricultural Engineers Handbook, McGraw-Hill, New York, 1961.
15. Richey, C.B. and S.D. Parsons., Development of a Self-Loading Transport Trailer for Large Round Bales. Trans. ASAE, Vol. 18, No. 6, 1975 pp. 1047-1050.
16. Rudnucki, J.M., "A Scientific Approach to the Design of Wooden Containers and the Design and Use of Pallets". Paper presented at Eastern Canadian Section of Forest Products Research Society Meeting, Ottawa, March 1954.
17. Rudnucki, J.M., Design of Containers and Interior Packing. Department of Forestry Technical Note 22, Ottawa.
18. Saskatchewan Department of Agriculture, Forage Harvesting and Hauling Comparisons. Economics and Farm Management Report, August 1977.
19. U.S.D.A. Marketing Service, Wholesale Fruit and Vegetable Warehouses. Report 467, August 1961.
20. U.S.D.A. Marketing Service, Handling and Shipping Potatoes to Processing Plants in Pallet Boxes and Burlap Bags. Report 495, September 1961.
21. U.S. Navy, Specifications for Department of Supplies and Accounts.

LIBRARY / BIBLIOTHEQUE



AGRICULTURE CANADA OTTAWA K1A 0C5

3 9073 00022014 7

